

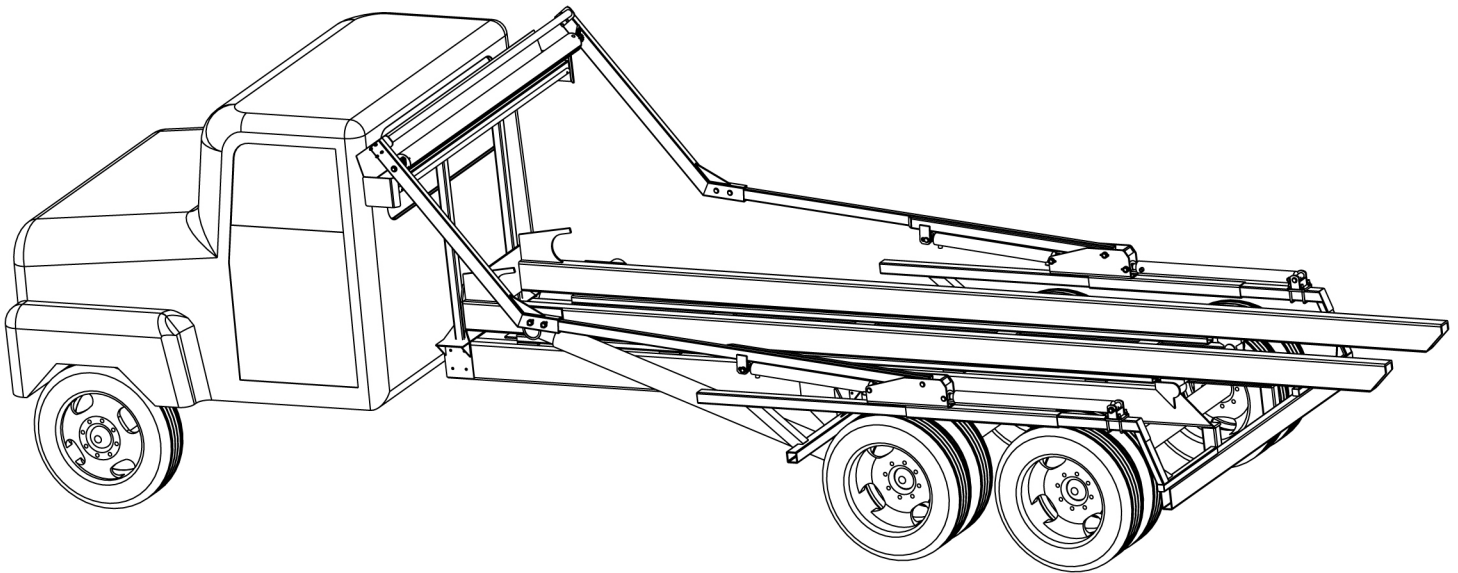

# INSTALLATION INSTRUCTIONS



## **OWNER'S MANUAL**

MARCH 2011

DeBrovy's, 9016 Taylorsville Rd #108, Louisville KY 40299

800-718-2777

[www.debrovys.com](http://www.debrovys.com)

PAGE 1 OF 30

03/21/2011



Automatic rolloff tarp system

**NON-TELESCOPIC GANTRY  
(KIT #3074)**

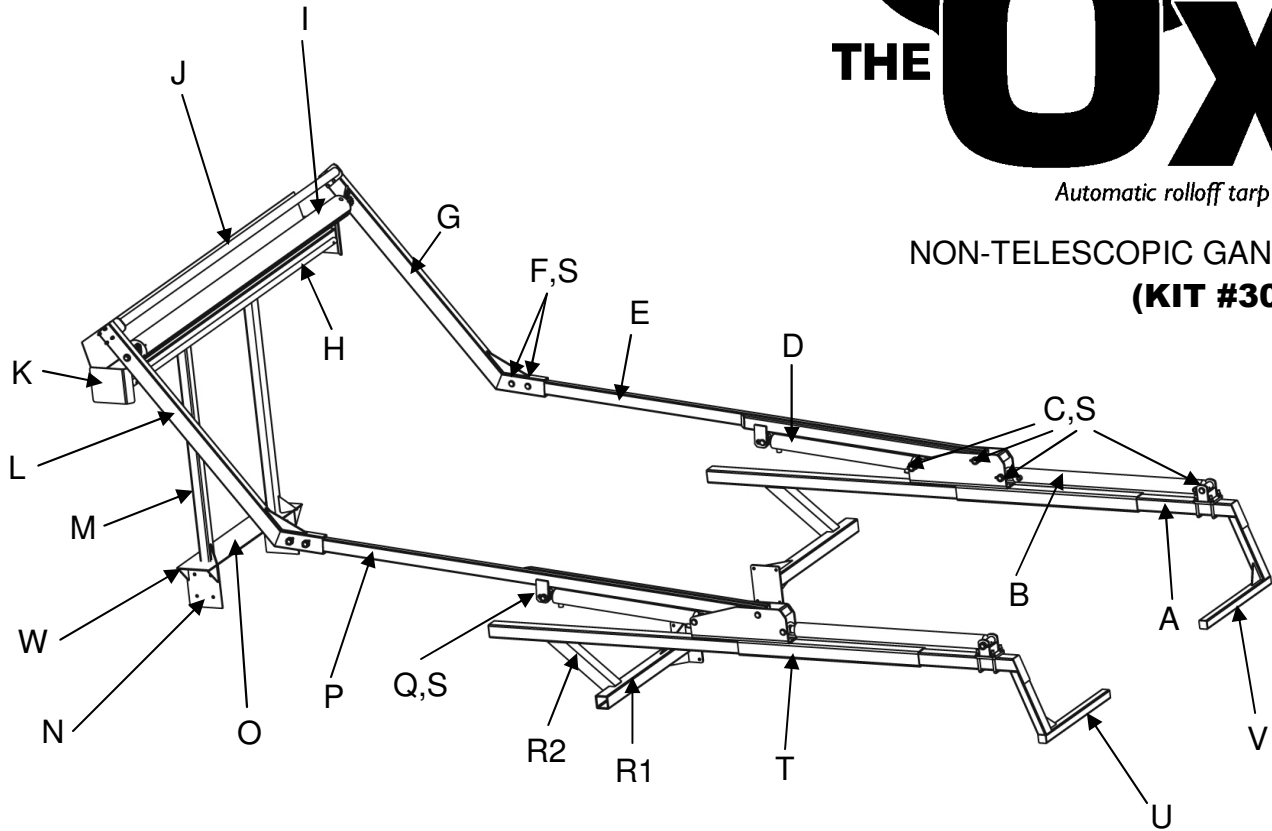

BALLOON	PART NUMBER	QTY	DESCRIPTION
A	3089	2	PIVOT BASE ASSEMBLY
B	3071HP	2	SLIDE CYLINDER
C	3128	8	PIN (FOR CYLINDERS)
D	3070HP	2	ARM CYLINDER
E	3136	1	LOWER TARP ARM - RIGHT
F	3131	4	UPPER ARM PIN
G	3154	1	UPPER TARP ARM ASSEMBLY - RIGHT
H	3078	1	TARP TUBE
I	2762	1	ROLLER BAR ASSEMBLY
J	3095	1	OFFSET TORSION BAR ASSEMBLY
K	3068	1	TARP CRADLE ASSEMBLY
L	3149	1	UPPER TARP ARM ASSEMBLY - LEFT
M	4344	1	FIXED GANTRY / INNER STAGE WELDMENT
N	3114	2	GANTRY SUPPORT ASSEMBLY
O	3127	1	GANTRY MOUNTING PLATE
P	3137	1	LOWER TARP ARM - LEFT
Q	3132	2	LOWER ARM PIN
R1	4234	2	BASE MOUNT
R2	4239	2	FRONT BRACE
S	3130	10	LOCK RING
T	3079	2	SLIDE MOUNT ASSEMBLY
U	3117	1	REAR SLIDE BRACE ASSEMBLY - LEFT
V	3118	1	REAR SLIDE BRACE ASSEMBLY - RIGHT
W	3113	4	GANTRY GUSSET



Automatic rolloff tarp system

**TELESCOPIC GANTRY  
(KIT #3075)**

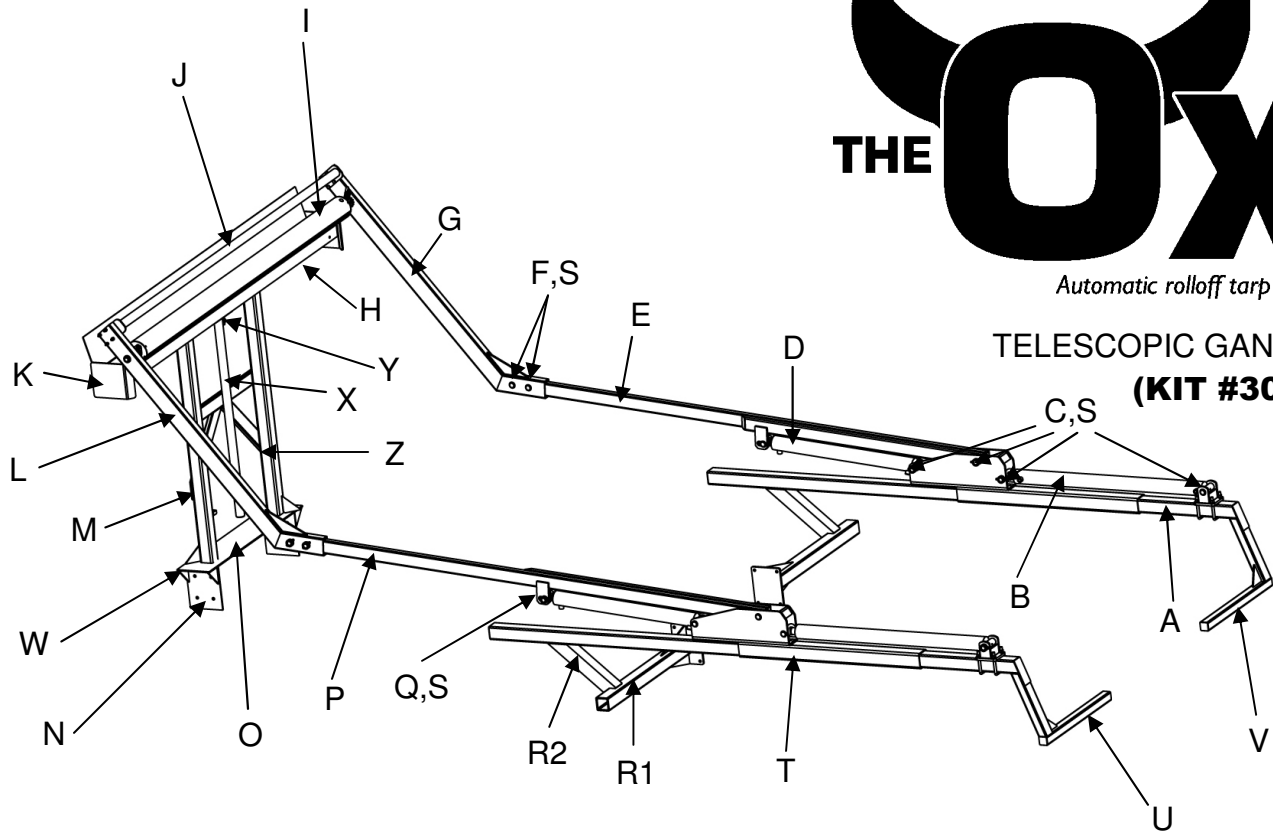

BALLOON	PART NUMBER	QTY	DESCRIPTION
A	3089	2	PIVOT BASE ASSEMBLY
B	3071HP	2	SLIDE CYLINDER
C	3128	8	PIN (FOR CYLINDERS)
D	3070HP	2	ARM CYLINDER
E	3136	1	LOWER TARP ARM - RIGHT
F	3131	4	UPPER ARM PIN
G	3154	1	UPPER TARP ARM ASSEMBLY - RIGHT
H	3078	1	TARP TUBE
I	2762	1	ROLLER BAR ASSEMBLY
J	3095	1	OFFSET TORSION BAR ASSEMBLY
K	3068	1	TARP CRADLE ASSEMBLY
L	3149	1	UPPER TARP ARM ASSEMBLY - LEFT
N	3114	2	GANTRY SUPPORT ASSEMBLY
O	3127	1	GANTRY MOUNTING PLATE
P	3137	1	LOWER TARP ARM - LEFT
Q	3132	2	LOWER ARM PIN
R1	4234	2	BASE MOUNT
R2	4239	2	FRONT BRACE
S	3130	10	LOCK RING
T	3079	2	SLIDE MOUNT ASSEMBLY
U	3117	1	REAR SLIDE BRACE ASSEMBLY - LEFT
V	3118	1	REAR SLIDE BRACE ASSEMBLY - RIGHT
W	3113	4	GANTRY GUSSET
X	420	1	GANTRY CYLINDER
Y	3395	1	CYLINDER TO HOUSING ADAPTER
Z	4345	1	TELESCOPING GANTRY

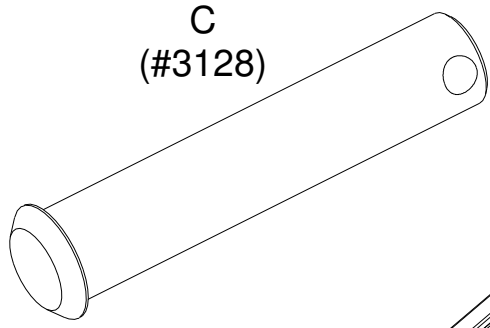
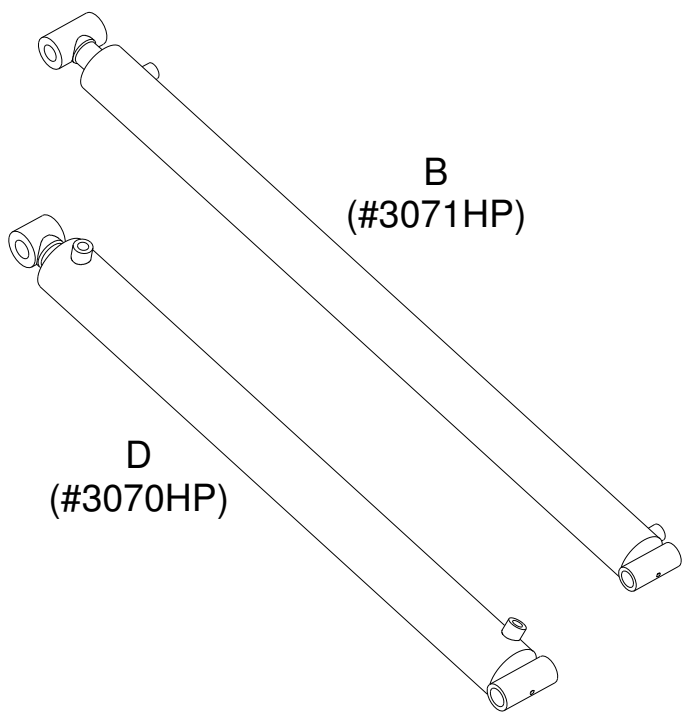
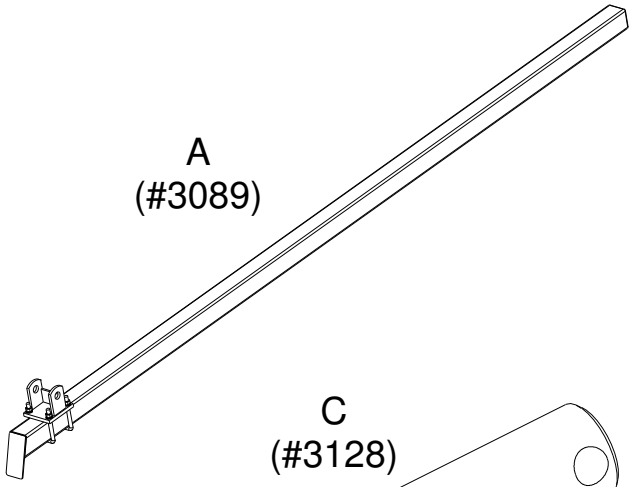

D  
(#3070HP)

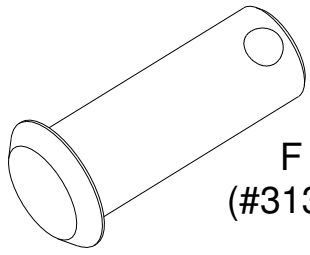
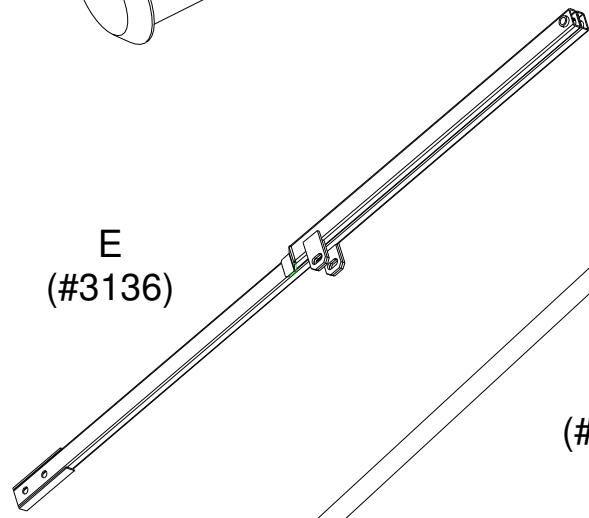

H  
(#3078)

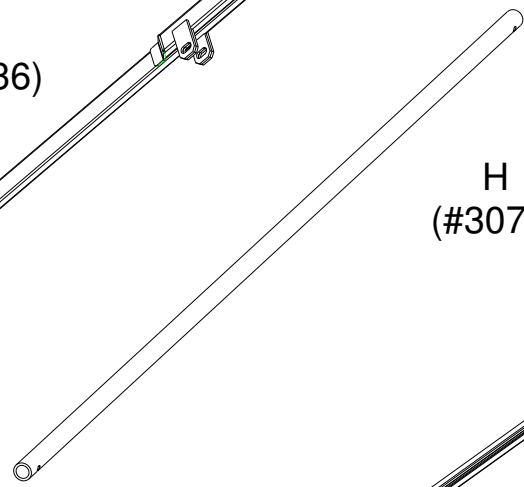

I  
(#2762)

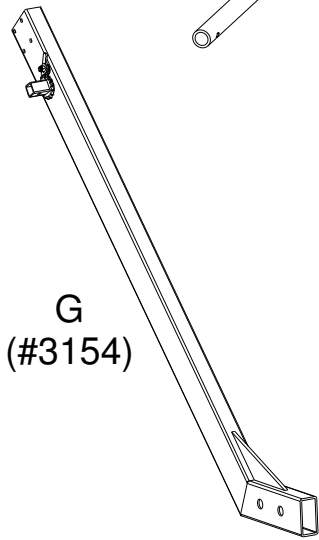
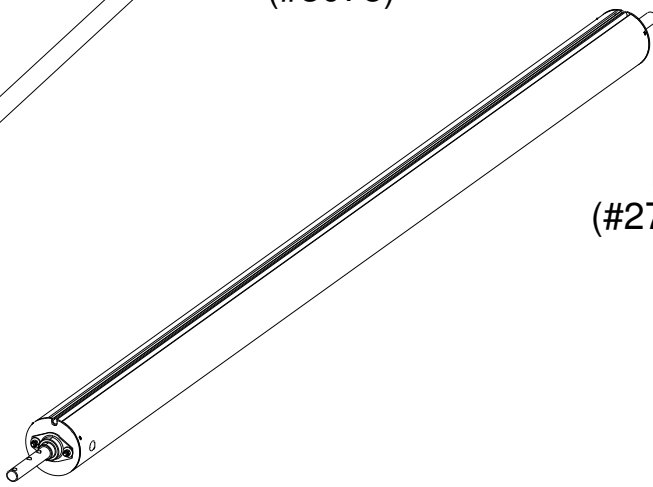

J  
(#3095)

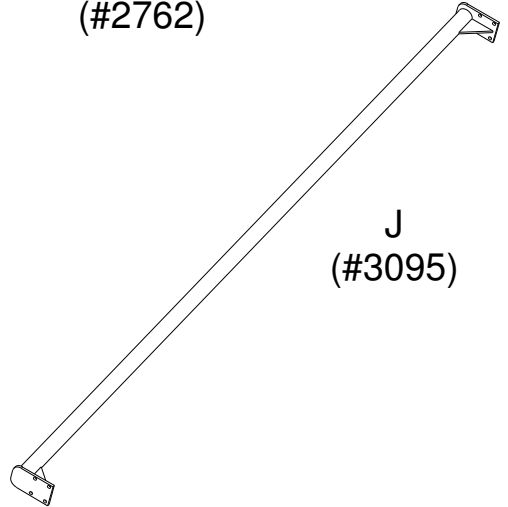

K  
(#3068)

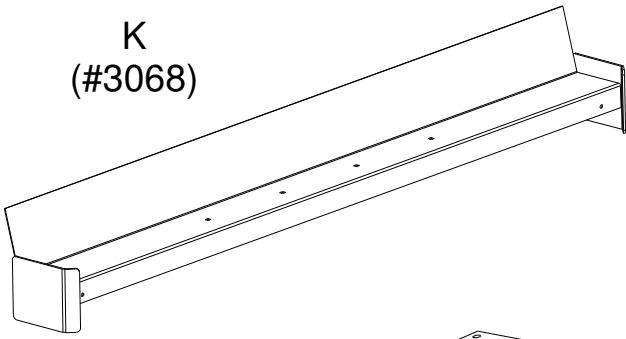

S  
(#3130)

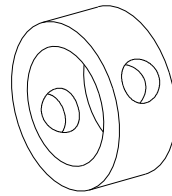

L  
(#3149)

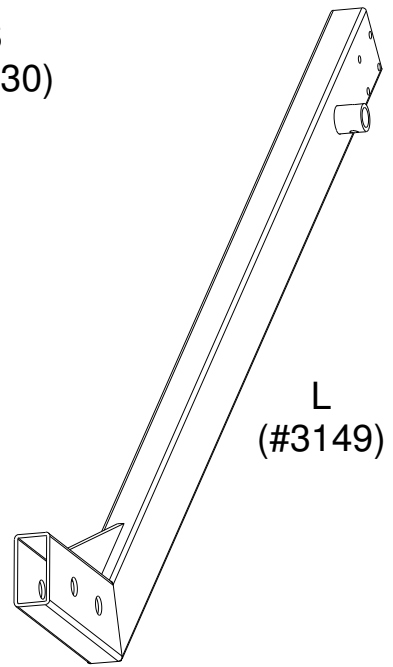

N  
(#3114)

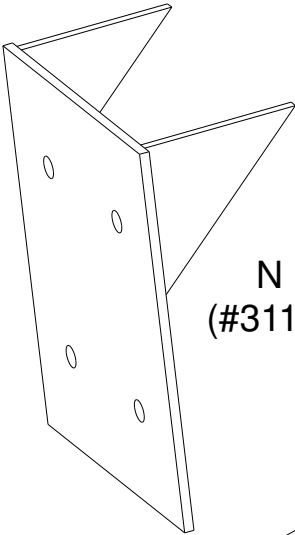

M  
(#4344)

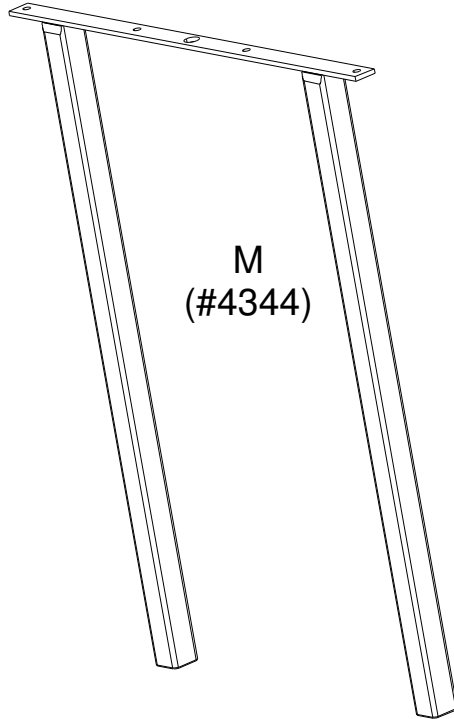

R2  
(#4239)

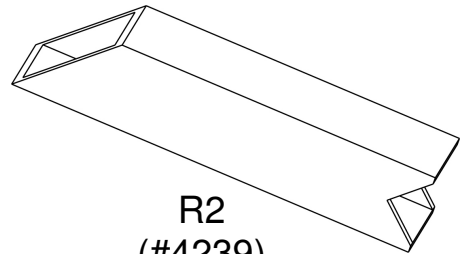

Q  
(#3132)

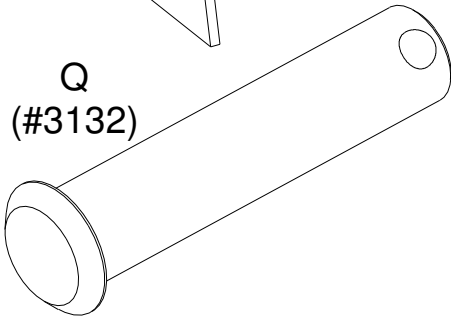

R1  
(#4234)

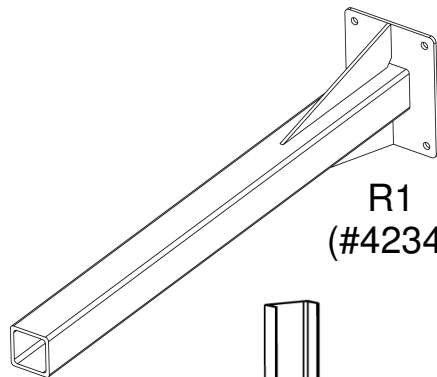

P  
(#3137)

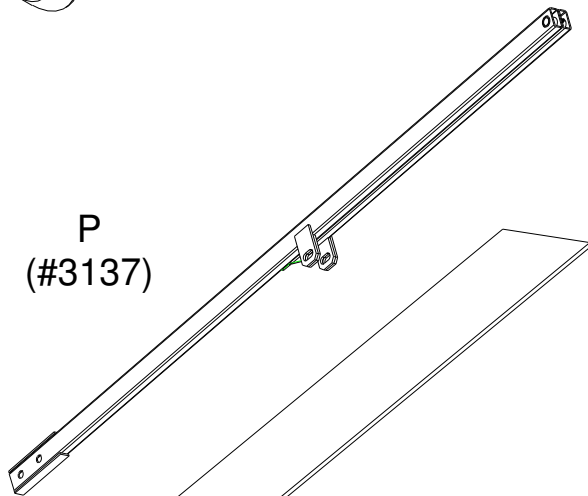

#4179



#3113

O  
(#3127)

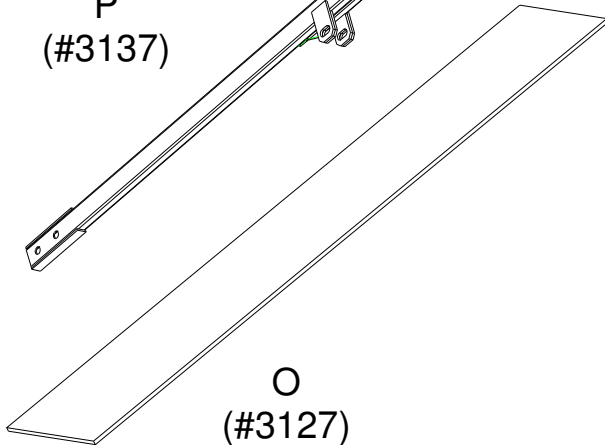

#4299

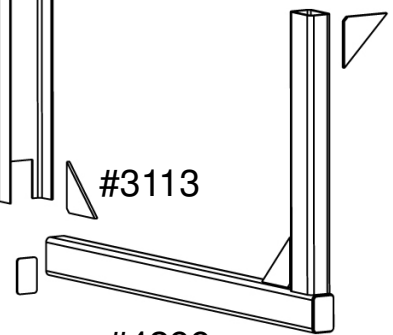

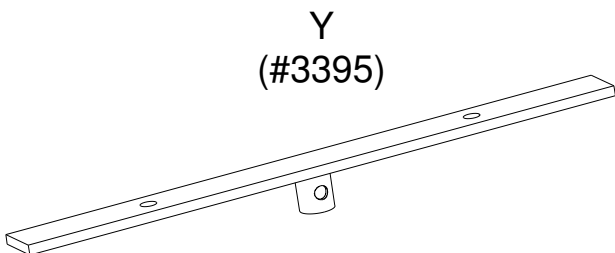
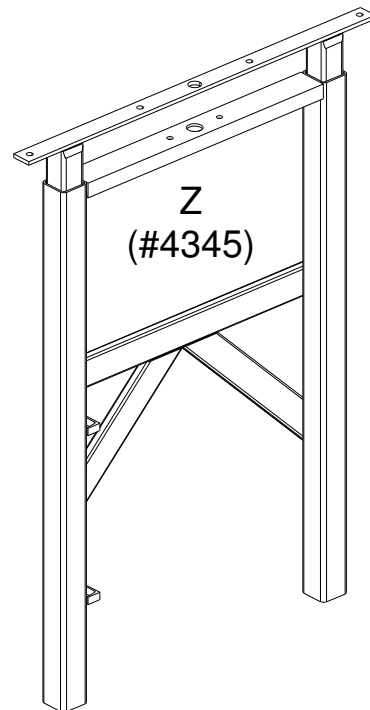
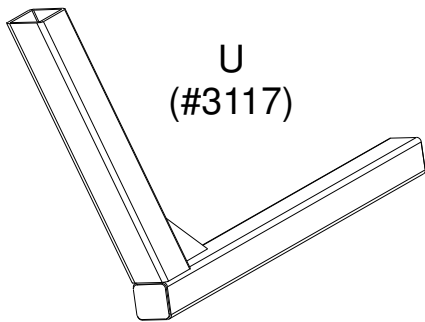
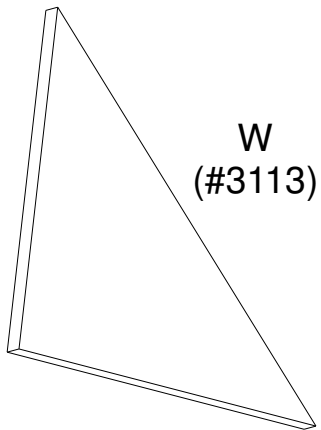
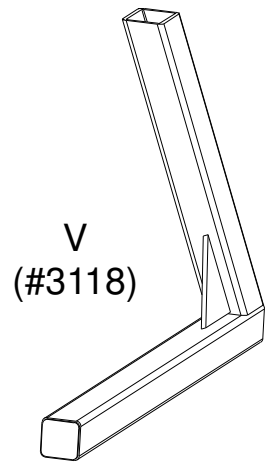
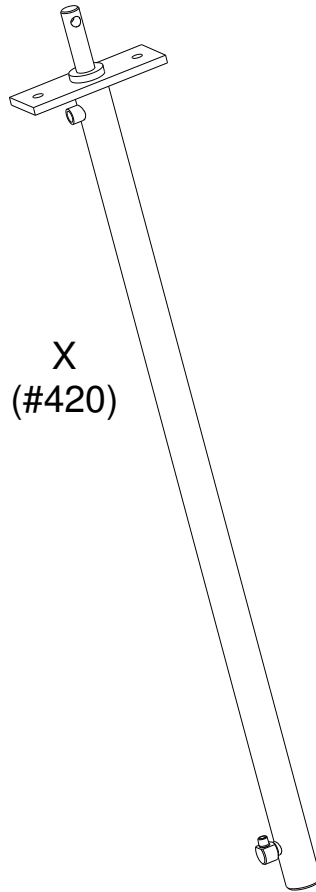
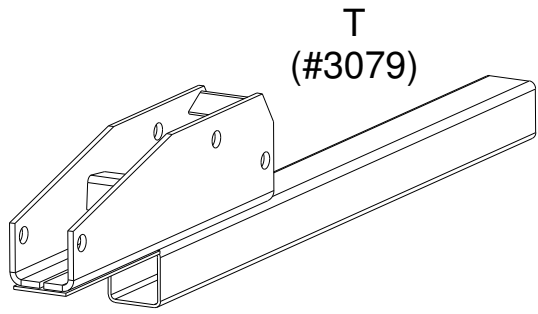

**IMPORTANT: PLEASE READ AND UNDERSTAND ALL  
INSTALLATION INSTRUCTIONS BEFORE STARTING INSTALL**

- A minimum clearance of 10” between the cab and the frame or bulkhead is required to fit the system on the truck
- Hydraulic hoses, hydraulic tanks, exhaust system, and other components may interfere with the standard mounting of system. Occasionally, special brackets may need to be fabricated by the installer to account for this interference.

**CAUTION:** When activating the control lever make sure that moving parts are in view.

**CAUTION:** When operating system make sure that no one is present on the side that is not in your direct view.

**CAUTION:** Make sure the truck is not under power lines when raising the tower, or operating the arms.

**CAUTION:** Before servicing or repairing the system, disconnect power to the components from the vehicles battery.

**NOTE:** The noise level is less than 72dB(A)

---

The following views (below and next page) show the covering system installed.  
The dimensions shown are to be referenced throughout the installation.

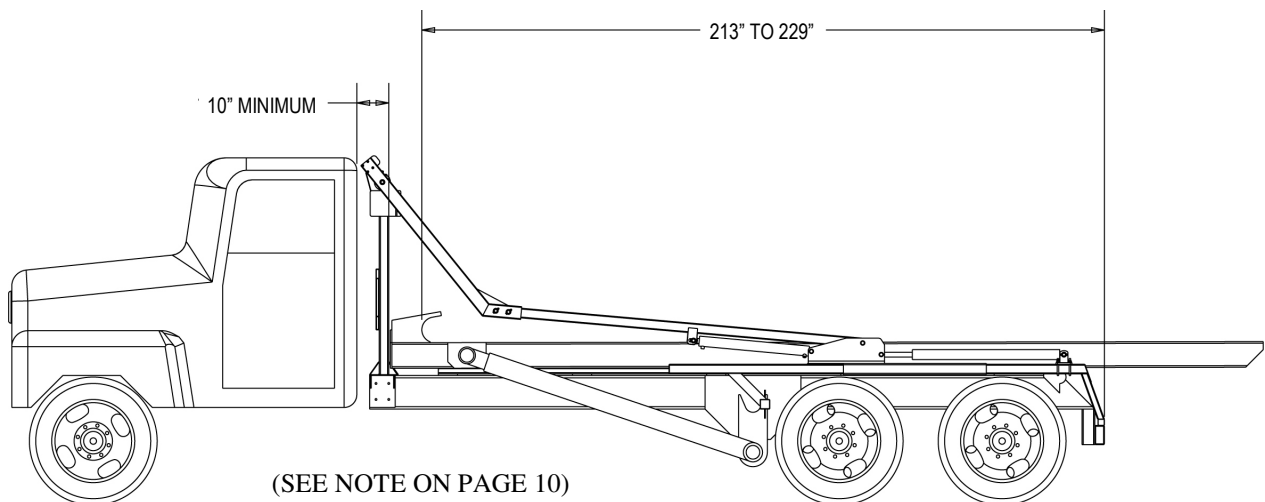

Center the two gantry support assemblies (part 3114) in the space between truck cab and hoist with the top edge level with the top of the frame rail. Use pre-drilled holes as guide to drill holes in frame and bolt into place using 1/2" SAE grade 8 bolts and 1/2" lock nuts (installer may need to provide hardware if length of bolts provided with kit are not optimal). Place the gantry mount plate (part 3127) on top of gantry support assemblies centered side to side and front to rear. Weld plate in place.

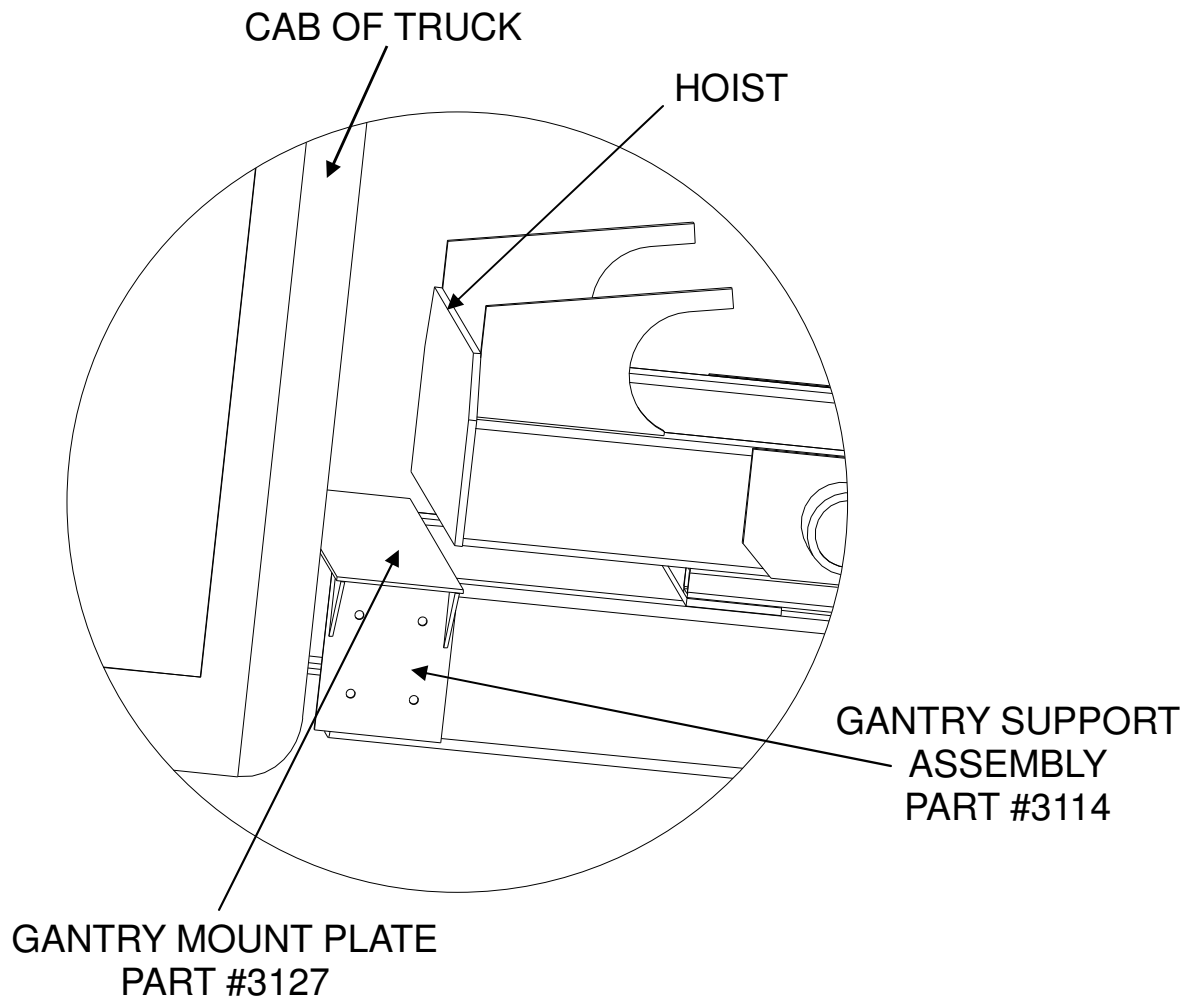
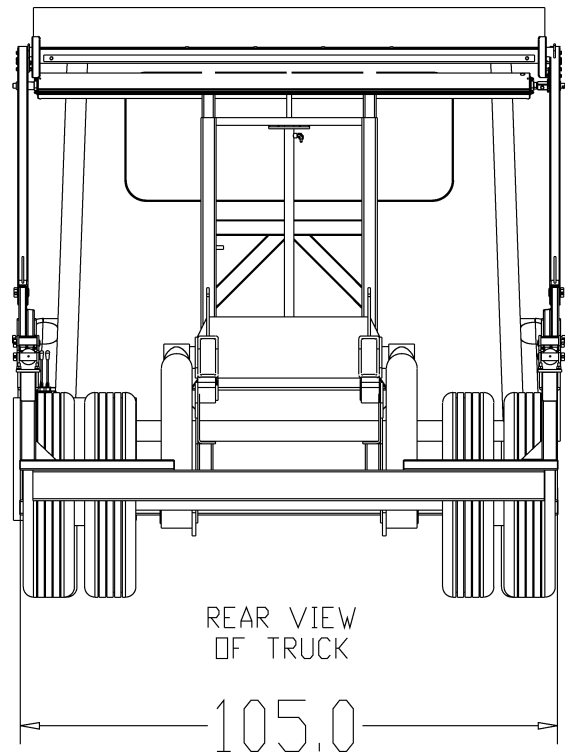



Weld both gantry legs to gantry mount plate as shown to the right. Make sure leg is minimum 5" from cab of truck and minimum of 2" from hoist and centered side to side on plate. Use four gussets (part 3113) supplied as a minimum to give gantry sufficient bracing.

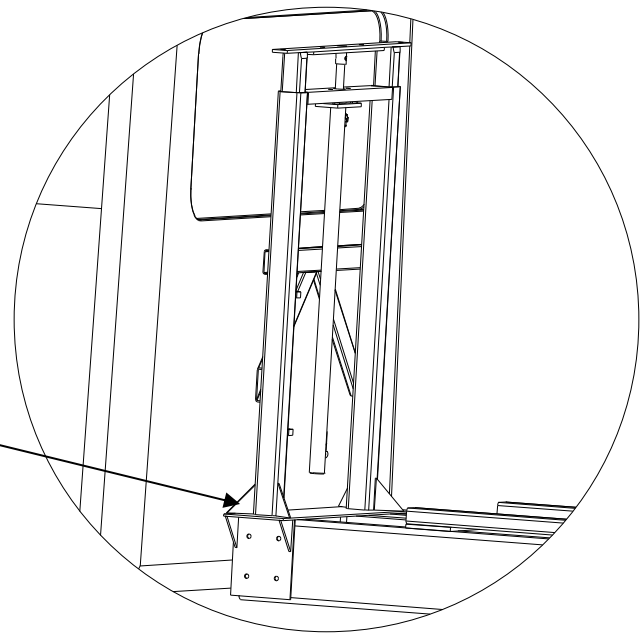

GANTRY GUSSETS  
PART #3113

FIXED GANTRY PART #4344  
TELESCOPING GANTRY PART #4345  
(TELESCOPING GANTRY SHOWN ABOVE)

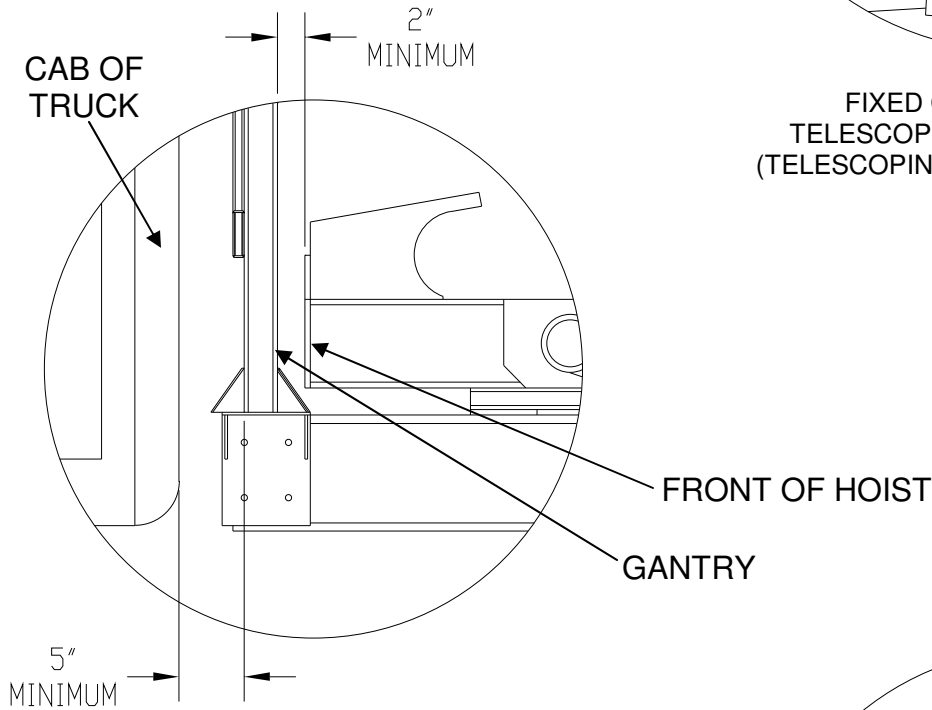

1/2"-13 X 1-1/2"  
CARRIAGE BOLTS

CRADLE  
PART #3068

Telescopic gantry only: Make sure the cylinder to housing adapter (part 3395) is attached to end of cylinder with 1/2" x 1 3/4" bolt and lock nut.

All systems: Attach housing to gantry using four 1/2" x 1 1/2" carriage bolts and lock nuts as shown at right.

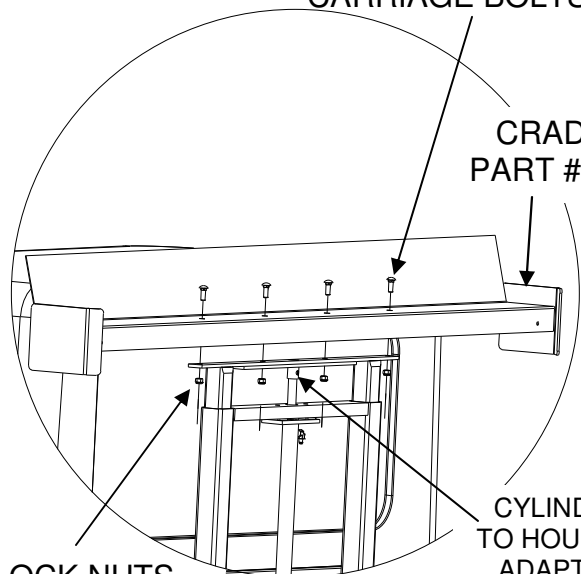

**Note:** If your rear bumper is not 213" to 229" from hoist stop as shown on page 7 you will need to modify the rear brace and fabricate supports to mount it to the frame so you can install the rear braces at this distance on your truck. For assistance, call Donovan engineering at 800-327-8287.

Raise the hoist and place a flat steel tube on sub frame and measure distance from bottom of this tube to top of left rear slide brace assembly. (Dim. Y below) This distance should be 2" plus or minus 1/2". You will need to either raise the assembly with shims or cut down the assembly if it is not at this height. Clamp the assembly in place.

**Note:** The distance from the bottom of the steel tube and the top of the left and right rear brace assemblies should be within 1/8" of each other.

Repeat this procedure for the left rear assembly, keeping the distance from the straight tube the same as the other side plus or minus 1/8". Clamp this assembly in place.

The distance from outside to outside of the two rear brace assemblies must be 105" (see dwg on page 8). The distance from the sub frame to the rear brace must be the same on both sides of the truck (this ensures the braces are centered on the truck.). Weld braces in place when all these dimensions have been verified.

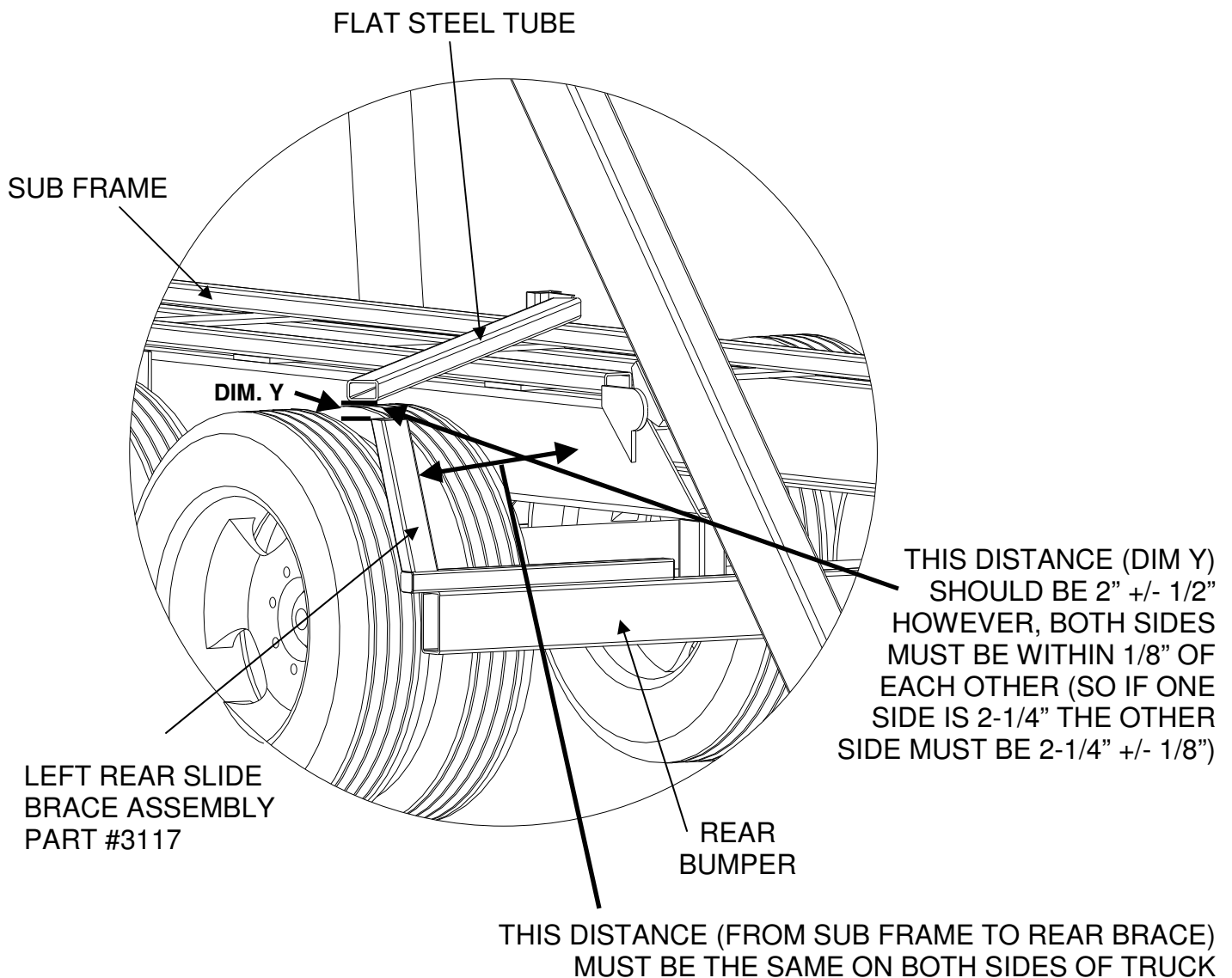

NOTE: The Federal DOT allows up to 108” width for safety equipment. Due to the clearance required on self contained compactors, this tarper is designed around the 108” maximum width. Trimming of part 4234 may be necessary to meet this requirement. The truck style will define the next step; please read the question below, and follow the appropriate front brace installation as needed.

- 1) Is this truck a Tri-Axle Truck/Hook Lift Truck?
  - a) Yes – See Tri-Axle/Hook Lift Front Brace Instructions
  - b) No – See Dual Axle Front Brace Instructions

### **Dual-Axle Front Brace Instructions**

The front brace should be a minimum 106.5” from the forward most point of the rear brace. If anything else shorter is required, the end user will not get the full range of motion offered by the OX system.

With smaller trucks, it is common to use the fender mount square tube for the tarping system. This is because the rotation of the hoist cylinders does not typically allow for anything mounted directly to the hoist subframe. We recommend this installation only when the 106.5” can not be met with the given components. If this method must be used, gusset the fender mount tubes appropriately.

NOTE: Raising the hoist completely at this point will help better understand where clearances can be met.

Weld components into place as shown below.

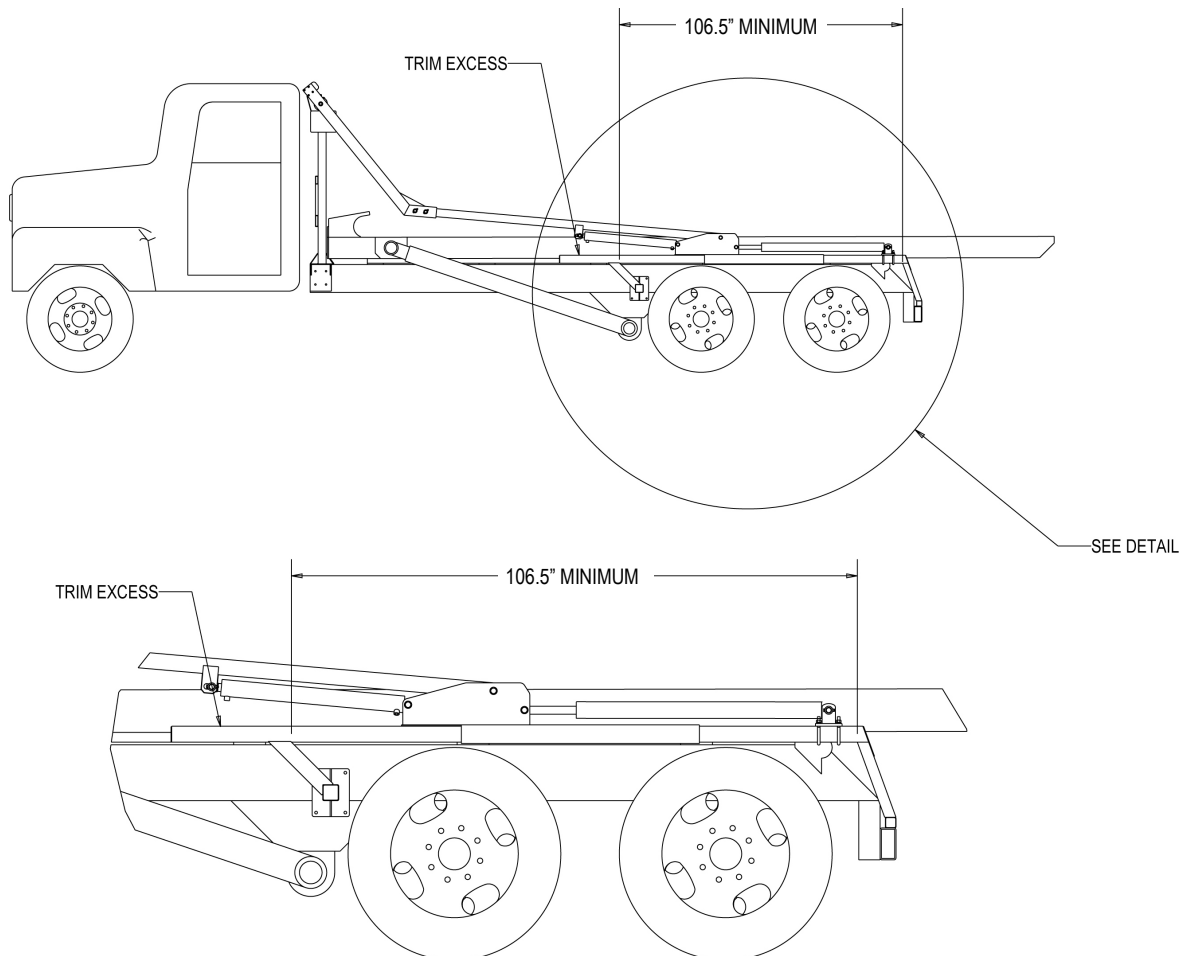

## TRI-AXLE/HOOK LIFT FRONT BRACE ASSEMBLY

**Note:** If you have a tri-axle truck the axle may be located at the same place where you need to install the front brace.

### OPTION 1 (recommended)

You may mount the front brace assembly forward of the lift axle (as shown below). The slide rail should be long enough to accommodate most modern lift axel trucks. Hook lift trucks can use these instructions as well because there is nothing obstruction the mounting of the front brace.

Install the front brace assembly forward of the tires are shown below. Attach the front brace to the sub frame by bolting or welding it into place.

Place a flat steel tube on sub frame and measure distance from bottom of this tube to top of modified support tube. (See diagrams below and on previous page) This distance must be the same distance that you measured for the rear brace +/- 1/8”.

### OPTION 2

You may mount the front brace assembly in between the tires. Follow the steps explained in Option 1 for mounting. Note: Be sure you are clear of all moving components.

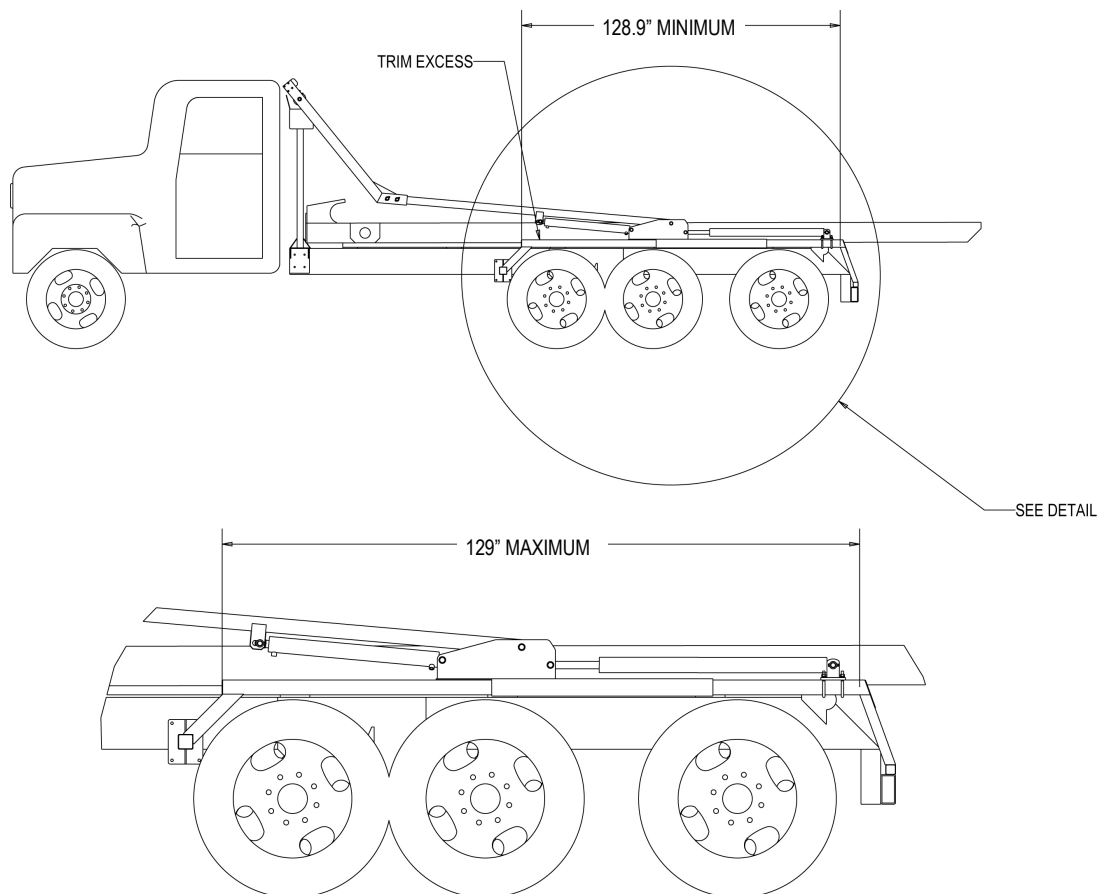

## **FRONT BRACE MODIFICATIONS**

The OX system was designed to accommodate as many truck sizes as possible. Because of this, the slide rail and the front brace were oversized. They must be trimmed to length prior to assembly. The front brace modification is as followed:

Measure the distance between the two hoist subframe rails. Now complete the calculation below:

$$\frac{(105 - \text{Hoist Width})}{2} = \text{Brace Length}$$

Trim the brace to *BraceLength*, attach the front brace as shown in the image below (you may have to trim the 45° brace as well):

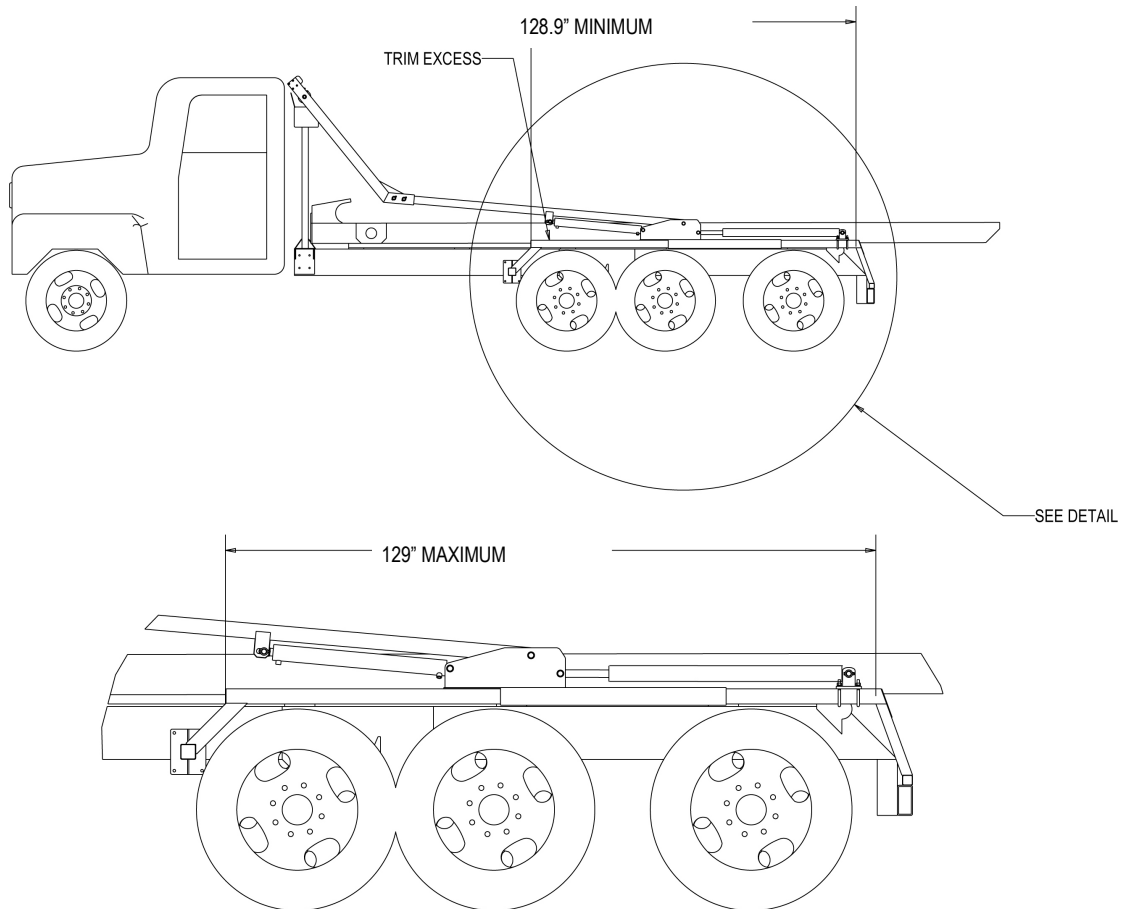

### **OPTION 3**

If the front brace assembly does not accommodate your truck specifications, use the two U-shaped bracket assemblies supplied. See images below.

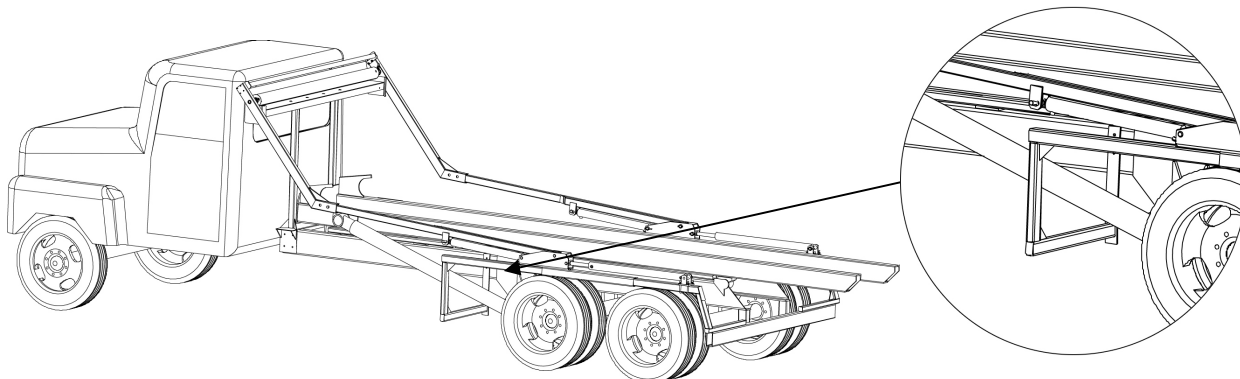

**CAUTION:** The slide mount assembly and pivot base assembly combined weigh approximately 125 Lbs. Use proper safe lifting practices when lifting and positioning mechanism.

**Note:** You must install slide mount assembly (part 3079) onto pivot base assembly (part 3089) prior to welding pivot base assembly in place. Refer to picture below to ensure parts are oriented correctly.

Install pivot base assembly on the front and rear brace centered side to side on the braces and as far forward as possible. Weld all around the front and rear brace where they make contact with the pivot base assembly.

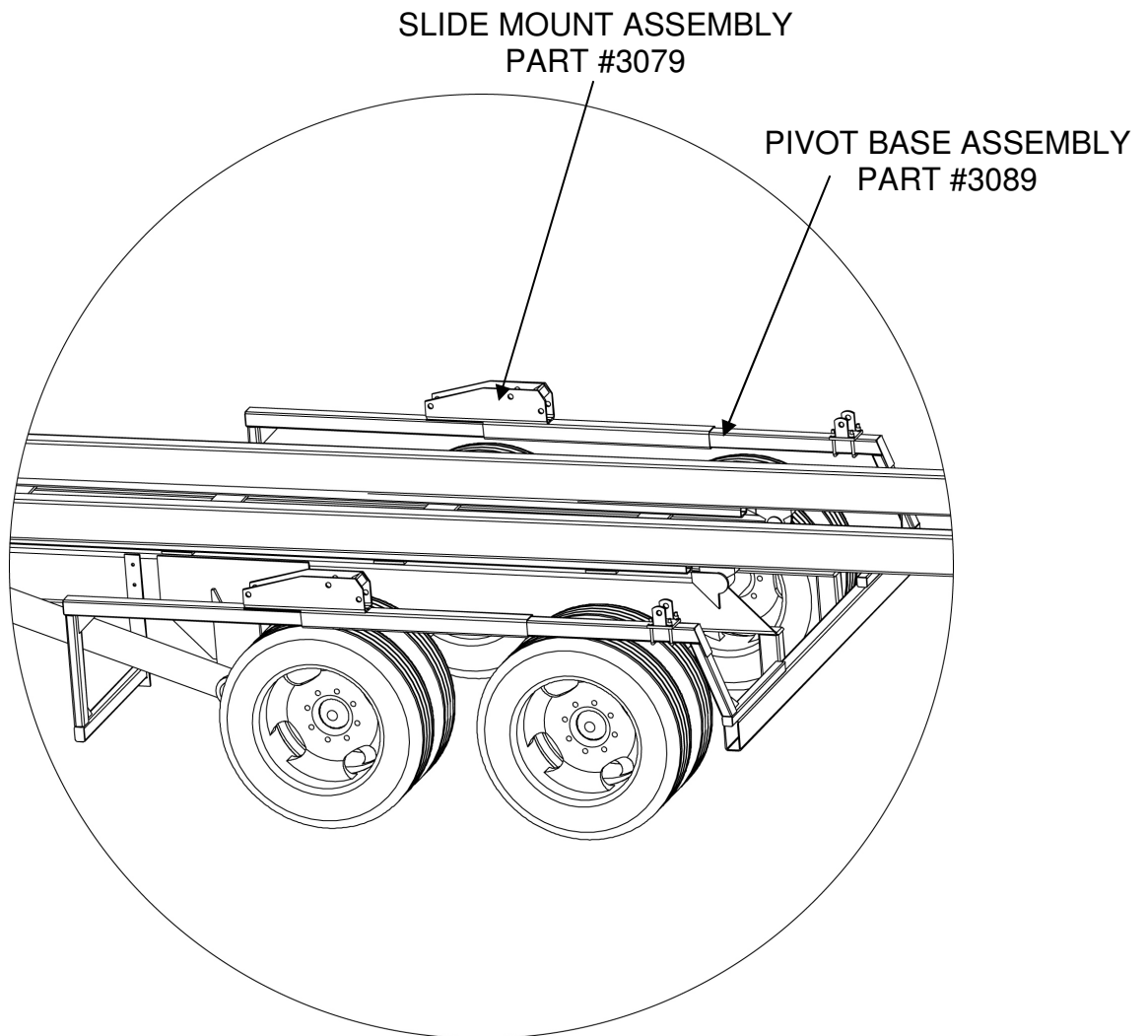

**Note:** When installing cylinder and arm pins, the head of the pin should be on the inside (toward frame of truck) and the lock ring on the outside of the parts. This will create a lower profile on the inside of the system to minimize containers catching on the system when loading and unloading containers.

Install both slide cylinders (part 3071HP) using pins (part 3128), lock rings (part 3130), 5/16" x 2" bolts and 5/16" lock nuts as shown below.

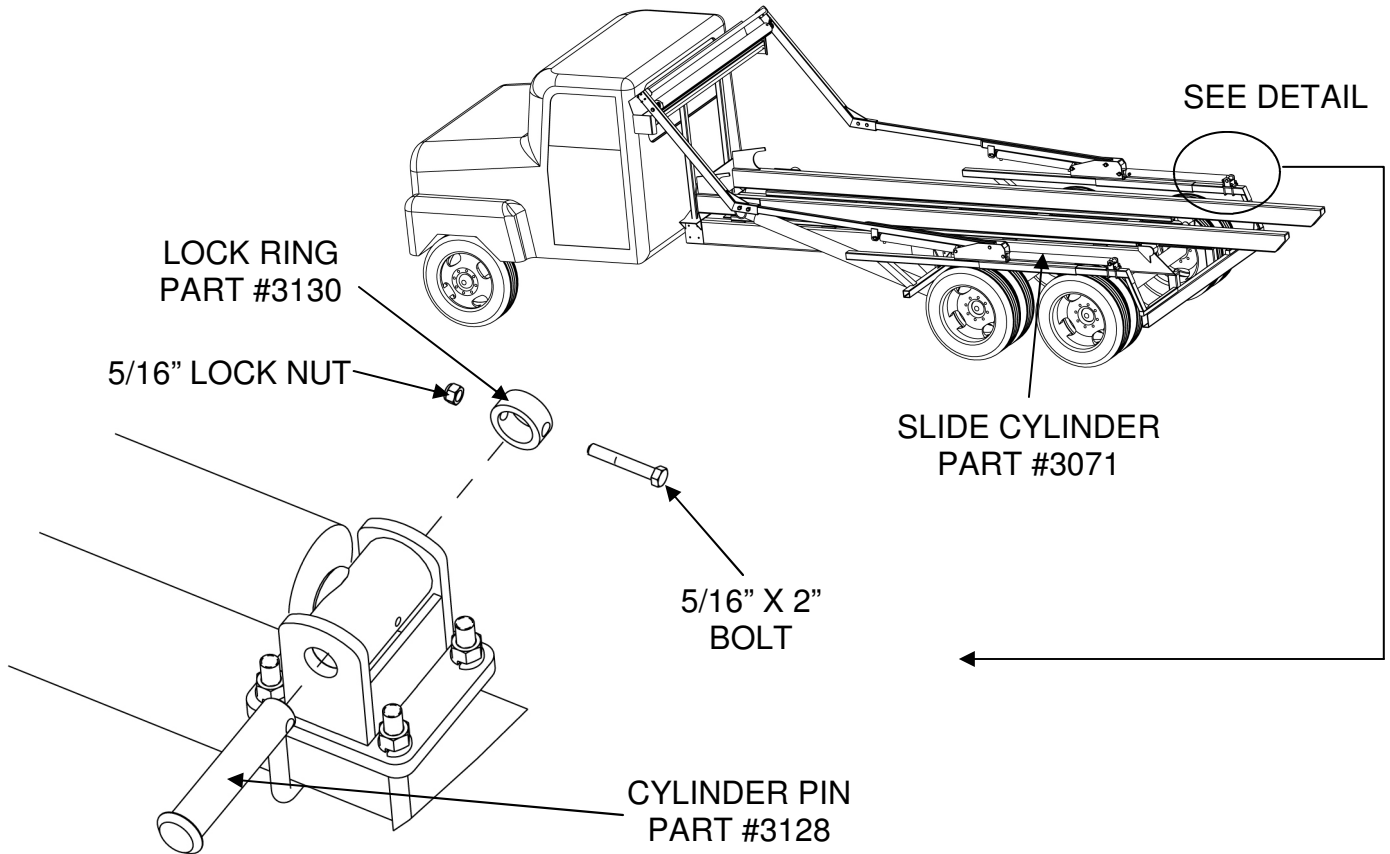

Install left arm (part 3137) and right arm (part 3136) and arm cylinders (part 3070HP) using pins (part 3128 and 3132), lock rings (part 3130), 5/16" x 2" bolts and 5/16" lock nuts as shown below.

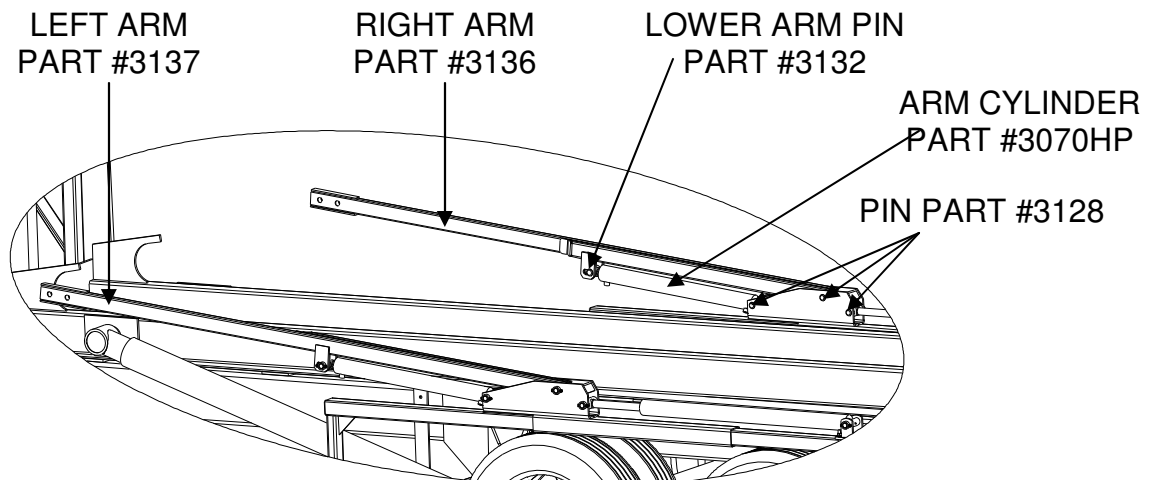

Install left upper arm (part 3149) and right upper arm (part 3154) using pins (part 3131), 5/16" x 2" bolts and 5/16" lock nuts as shown below.

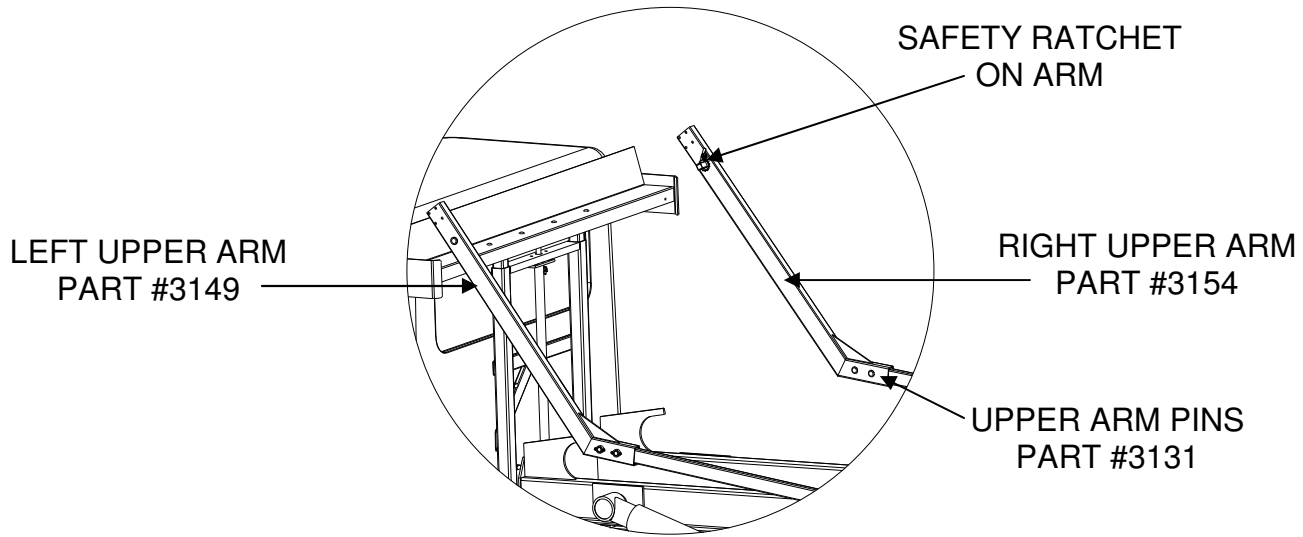

**CAUTION:** The end of the roller bar with the sticker and carriage head bolt will be attached to the ratchet on the upper right side arm as shown below. Installing in the wrong direction may damage the spring and void the warranty.

Slide the roller bar shaft into the left and right upper arms. Use a 3/8" x 2" bolt and lock nut to secure the roller shaft into the square ratchet tube.

**Note:** The roller bar may need to be repositioned on the roller shaft to fit properly between the upper arms. This is accomplished by loosening the set screws on the shaft collars, and adjusting the roller on the shaft. Tighten all shaft collar set screws after roller bar is repositioned.

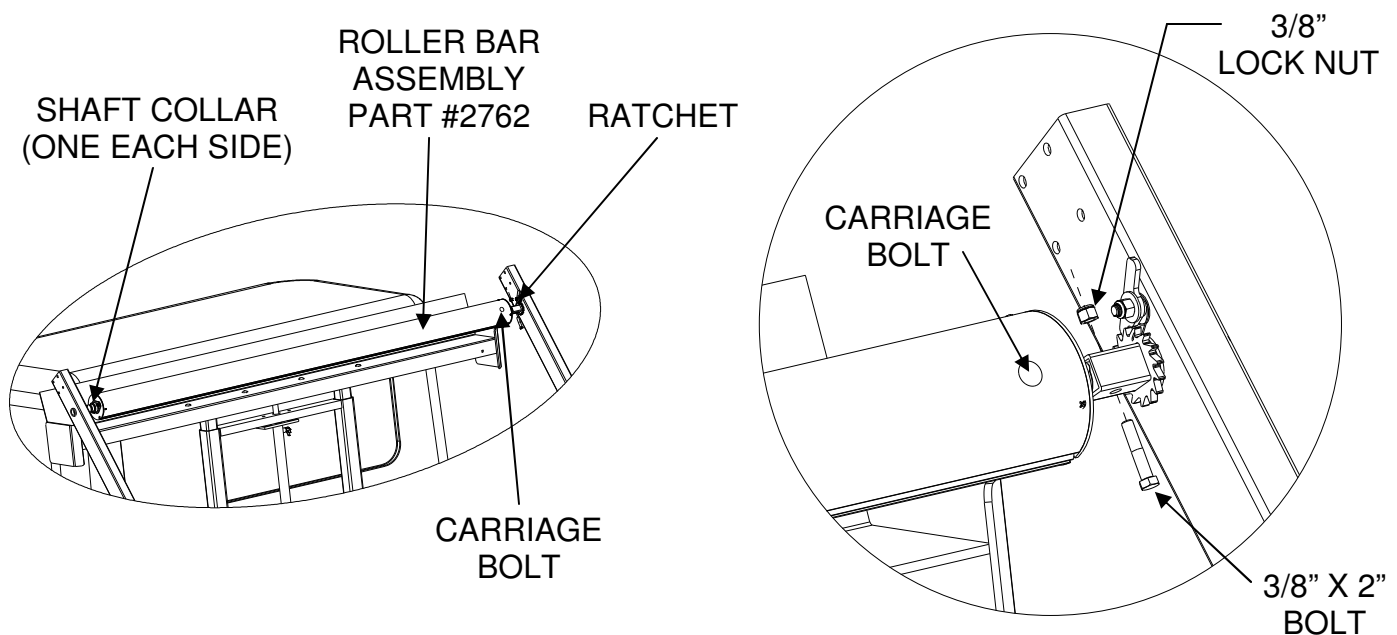



- Attach the torsion bar assembly between the two upper arms as shown using four (4) 3/8" x 3" bolts and nuts on both sides (eight total).

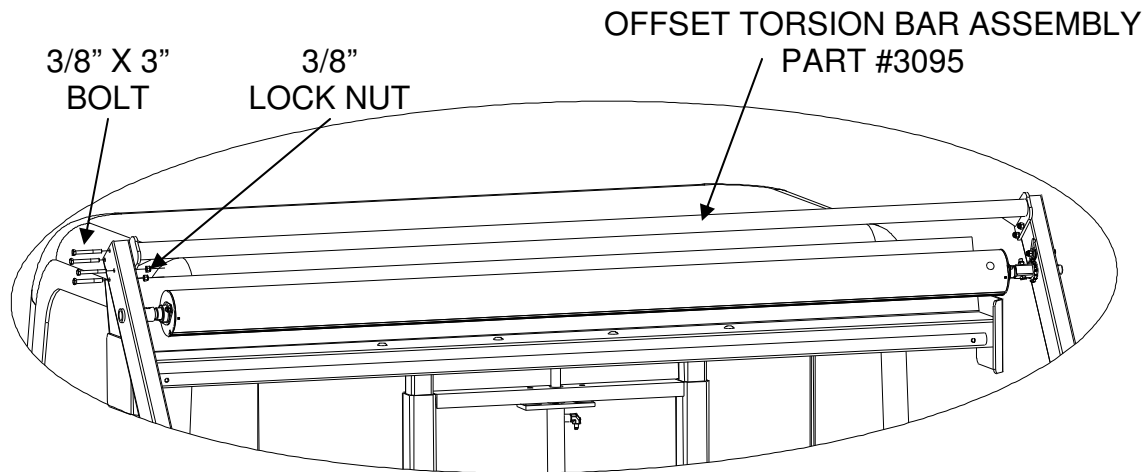

- Unfold tarp and lay lengthwise on hoist with white Donovan tag facing down and tarp pocket at front end of the hoist. Slide the tarp tube through the pocket in the tarp and attach to housing using two (2) 3/8" x 2" bolts and lock nuts. Slide spline end of tarp into the spline groove in the roller bar. Now grab opposite end of tarp with sewn-in spline and walk it forward toward cab.

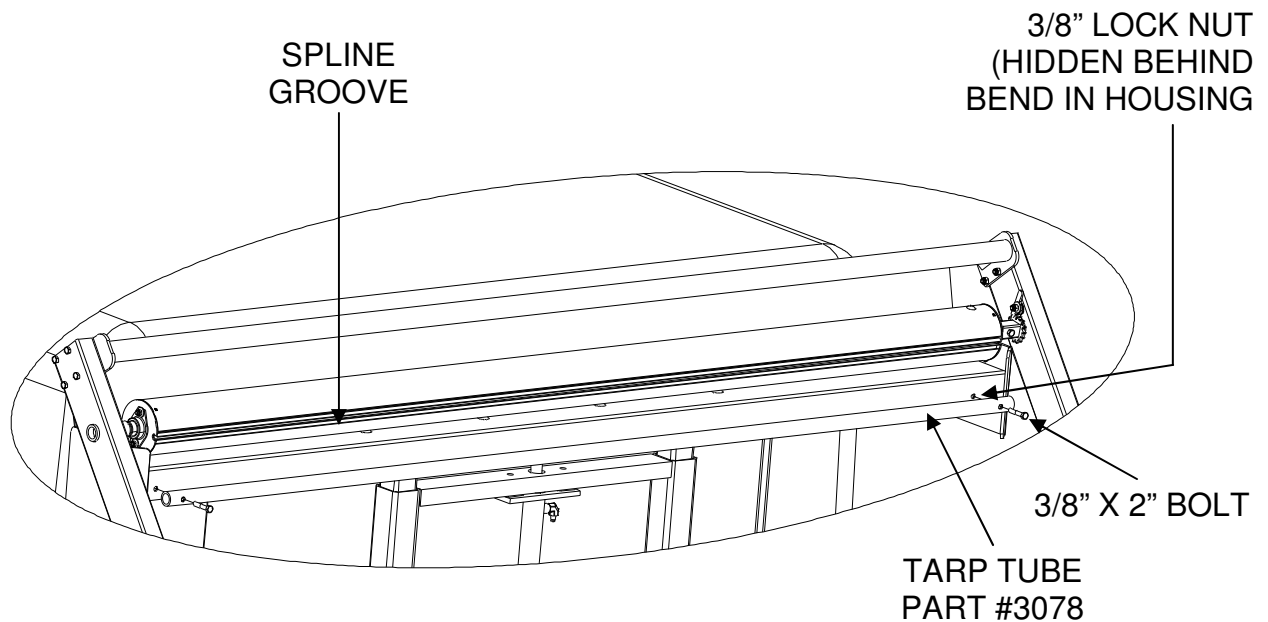

**CAUTION:** You must count each full turn of the roller shaft. Never exceed (35) complete turns on the ratchet mechanism. Exceeding 35 complete turns will damage spring and void warranty.

- Insert a 3/8" steel bar into the hole in roller bar shaft as shown below. Rotate the shaft in a clockwise direction to increase spring tension. Slowly feed in the tarp as you put on (35) complete turns.
- Use the hole in the left upper arm as a guide and drill a hole in the roller bar shaft once the tension is correct. Insert and tighten a 3/8" x 2" bolt and lock nut through the roller shaft. If you need to add some tension to the roller bar you will need to remove this bolt, but reinstall it after tension has been adjusted.

**Hint:** Have a second person rotate roller bar slightly to help align holes and insert bolt if you added more tension to the spring.

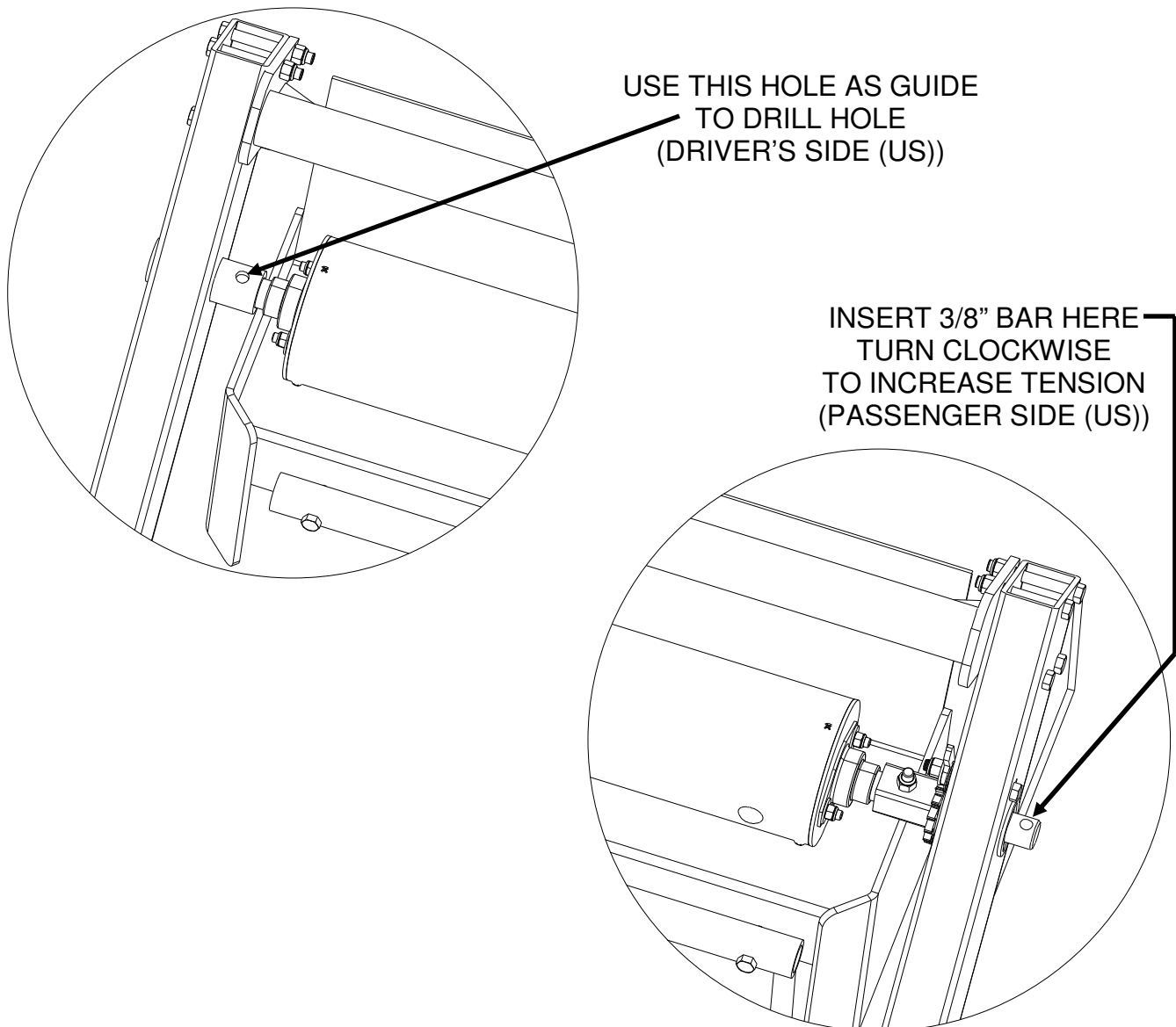

# Kit #3189 - Ox hydraulic component box (for #3074 - stationary gantry model)



**Part # 3174**  
1/4" x 15' hose (4)

**Part #3374**  
3gpm PFC Valve



**Fitting bag  
(small)**



**Part #3330**  
50/50 valve (2)

**Part #3329**  
2-spool control valve



**Fitting bag  
(large)**



**Part #3568**  
1" x 2' hose (1)



**Part #3177**  
1/4" x 12' hose (4)



**Part #3172**  
1/4" x 20' hose (4)



**Part #3169**  
3/8" x 5' hose (2)

# Kit #3187 - Ox hydraulic component box (for #3075 - telescoping gantry model)



**Part # 3174**  
1/4" x 15' hose (4)



**Part #3186**  
1/4" x 10' hose (2)



**Part #3568**  
1" x 2' hose (1)

**Part #3574**  
3gpm PFC valve



**Part #3330**  
50/50 valve (2)

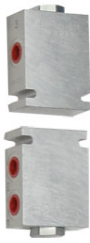

**Fitting bag**  
(small)



**Part #3328**  
3-spool control valve



**Fitting bag**  
(large)



**Part #3177**  
1/4" x 12' hose (4)



**Part #3172**  
1/4" x 20' hose (4)



**Part #3169**  
3/8" x 5' hose (2)

# STEPS FOR INSTALLING YOUR OX TARP SYSTEM HYDRAULICS KIT

- Mount the 50/50 diverter valves , flow control valve (if used), and spool valve (if used) in a suitable location for the driver to operate system.

**CAUTION:** (Advice for determining hose cut length) If you cut the upper hoses too long there is a chance that they will stick up and possible get caught on the container as you load or unload it.

- Look at the two diagrams on pages 22 and 24 to determine which one you will be using for your truck. Follow the chart and diagram that is for your truck to connect hoses to various components (see step below for cutting hoses). The hydraulic hoses going to the upper arm will need to have enough slack to be able to travel with the system. Make sure that you do not cut these hoses too short.
- All hoses are supplied with one end crimped so they can be cut to length. The other end will use a re-usable fitting. Follow the instructions below to install the re-usable fittings: Thread the re-usable fitting body (counter clockwise) on the cut end of each hose as shown below. Body will thread on approx. 1". **NOTE: body must be threaded completely into hose to prevent leaking.** Next thread the fitting insert into the body (clockwise) until it is snug against the fitting body as shown. **HINT:** A small amount of liquid soap will help the fitting insert into the body.

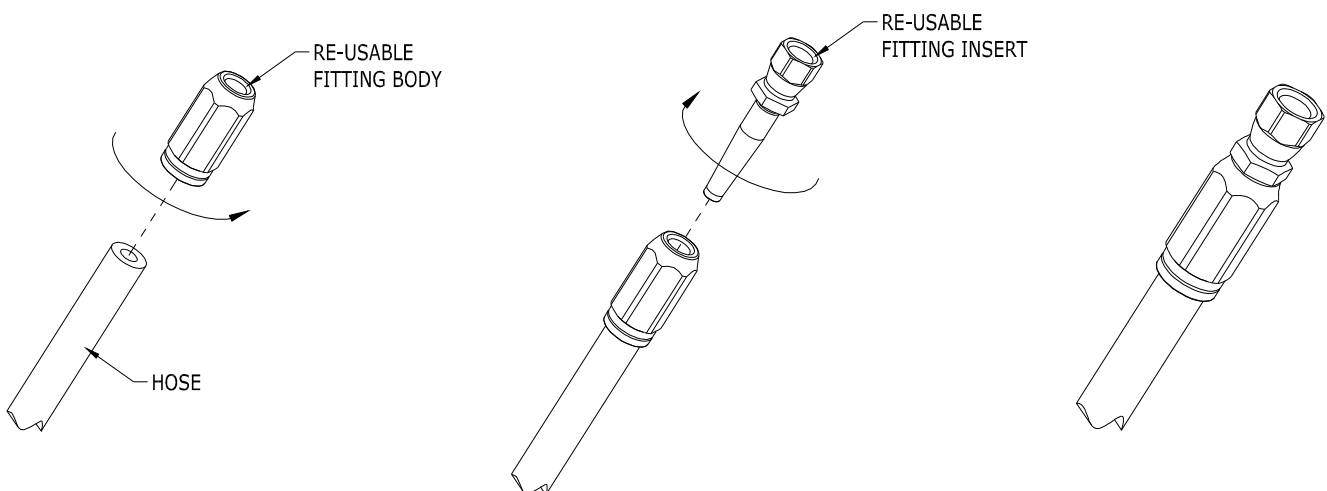

# HYDRAULIC SCHEMATIC FOR KIT #3074 OX SYSTEM - FIXED GANTRY

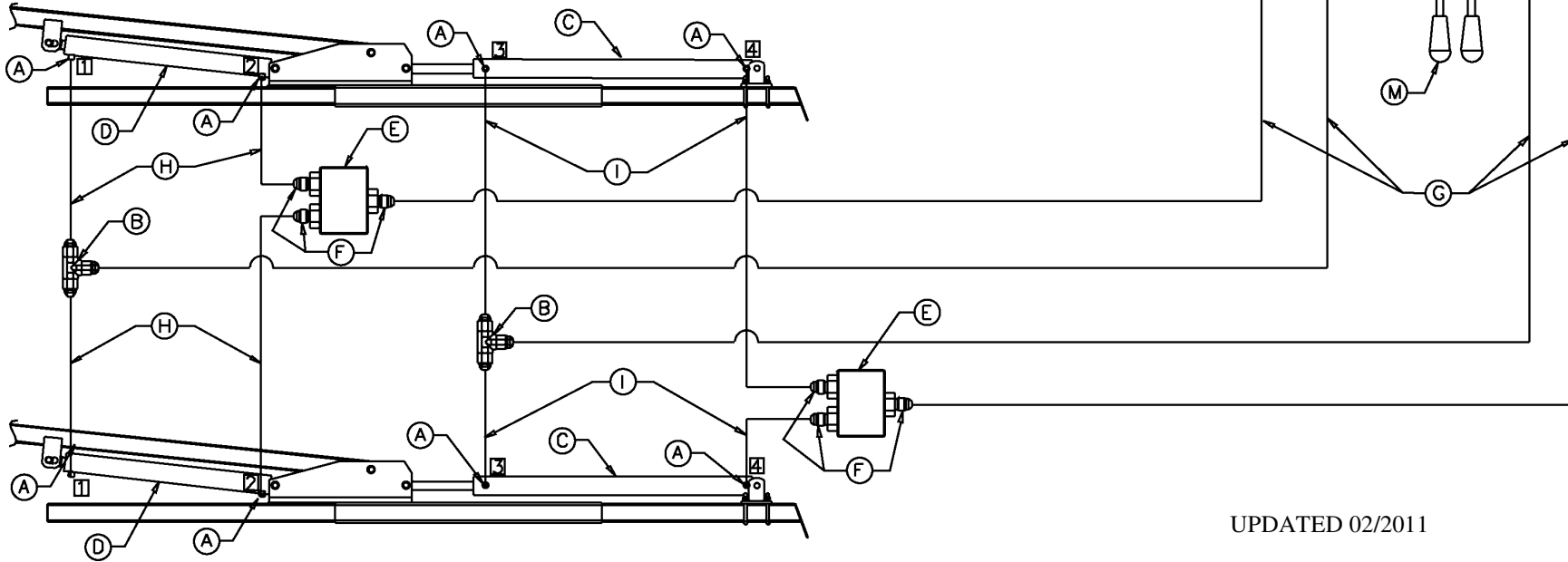
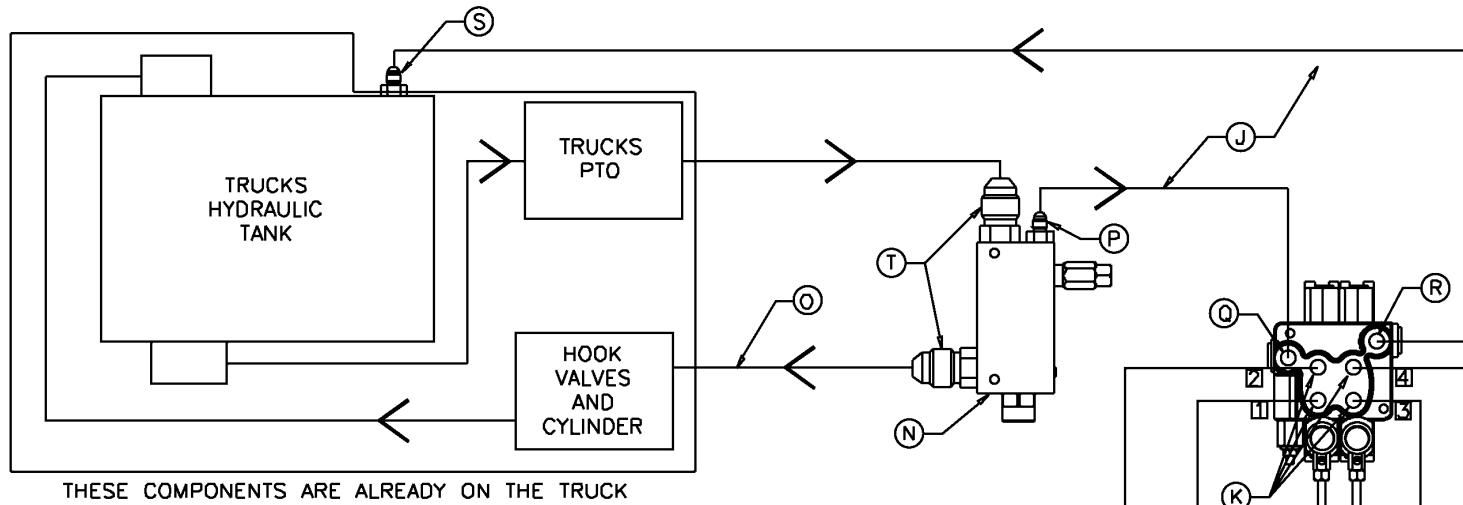

**HYDRAULIC PARTS LIST  
FOR KIT #3074 OX SYSTEM - FIXED GANTRY**

BALLOON NUMBER	PART NUMBER	DESCRIPTION	QUANTITY
A	3180	90 DEGREE FITTING (6MB X 4MJ)	8
B	3183	"T" FITTING	2
C	3071HP	SLIDE HYDRAULIC CYLINDER	2
D	3070HP	ARM HYDRAULIC CYLINDER	2
E	3330	50/50 CONTROL VALVE	2
F	3338	STRAIGHT FITTING (6MB X 4MJ)	6
G	3172	1/4" X 20' HOSE	4
H	3174	1/4" X 15' HOSE	4
I	3177	1/4" X 12' HOSE	4
J	3169	3/8" X 60" HOSE	2
K	3339	STRAIGHT FITTING (8MB X 4MJ)	4
M	3329	2 SPOOL CONTROL VALVE	1
N	3574	3 GPM PRIORITY FLOW CONTROL VALVE	1
O	3568	1" X 2' HOSE	1
P	4592	STRAIGHT FITTING (3/8MNPT X 6MJ)	1
Q	3185	STRAIGHT FITTING (6MB X 6MJ)	1
R	3566	STRAIGHT FITTING (10MB X 6MJ)	1
S	3567	STRAIGHT FITTING (6MB X 1/2 NPT, MALE)	1
T	3584	STRAIGHT FITTING (3/4MNPT X 16MJ)	2
SEE PAGE 21	3178	REUSABLE FITTING FOR 1/4" HOSE	12

# HYDRAULIC SCHEMATIC FOR KIT #3075 OX SYSTEM - TELESCOPING GANTRY

OX HYDRUALIC SCHEMATIC USING THREE SPOOL VALVE AND PRIORITY FLOW CONTROL VALVE

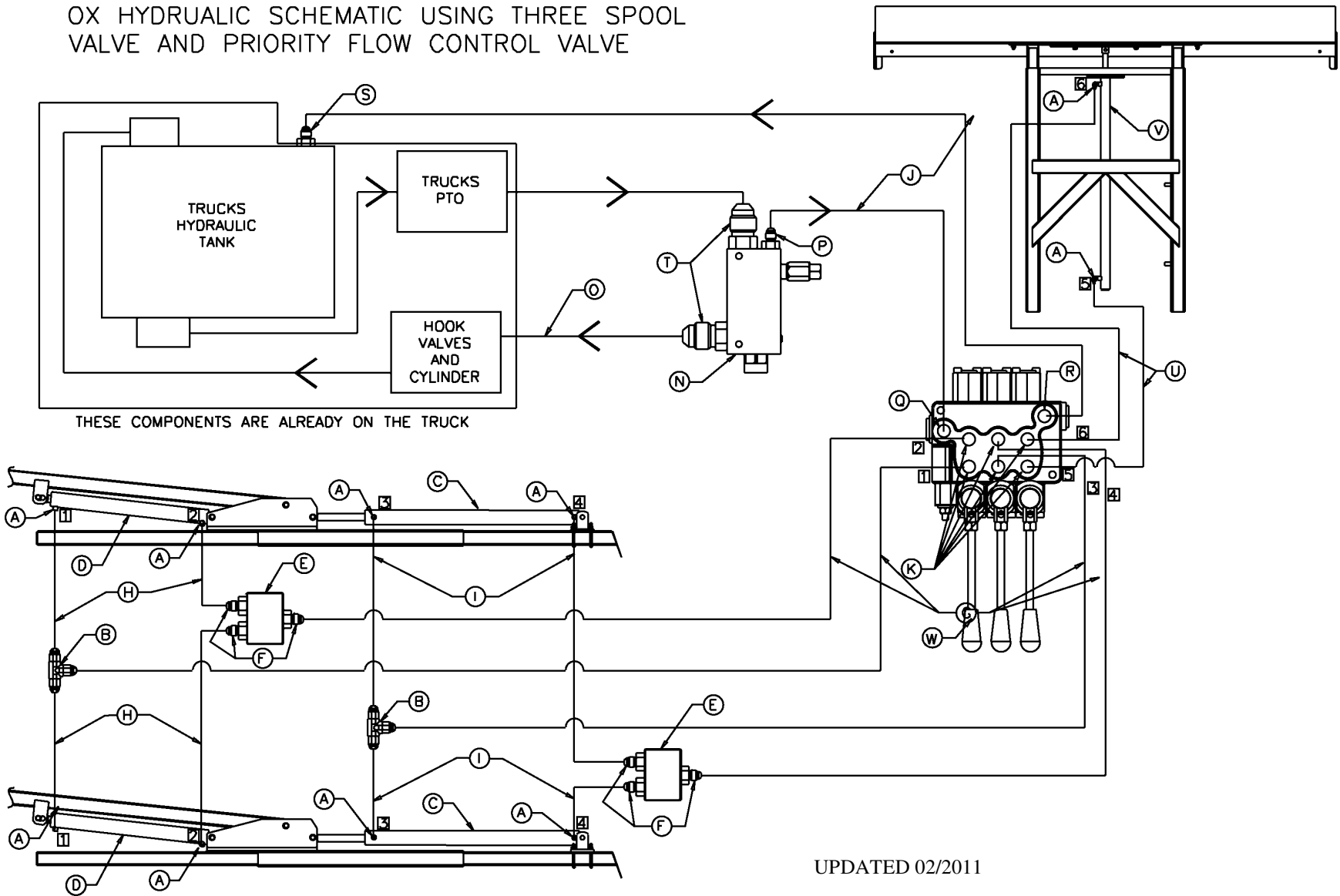

UPDATED 02/2011



**HYDRAULIC PARTS LIST  
FOR KIT #3075 OX SYSTEM - TELESCOPING GANTRY**

BALLOON NUMBER	PART NUMBER	NAME	QUANTITY
A	3180	90 DEGREE FITTING (6MB X 4MJ)	8
B	3183	"T" FITTING	2
C	3071HP	SLIDE HYDRAULIC CYLINDER	2
D	3070HP	ARM HYDRAULIC CYLINDER	2
E	3330	50/50 CONTROL VALVE	2
F	3338	STRAIGHT FITTING (6MB X 4MJ)	6
G	3172	1/4" X 20' HOSE	4
H	3174	1/4" X 15' HOSE	4
I	3177	1/4" X 12' HOSE	4
J	3169	3/8" X 60" HOSE	2
K	3339	STRAIGHT FITTING (8MB X 4MJ)	6
N	3574	3 GPM PRIORITY FLOW CONTROL VALVE	1
O	3568	1" X 2' HOSE	1
P	4592	STRAIGHT FITTING (3/8MNPT X 6MJ)	1
Q	3185	STRAIGHT FITTING (6MB X 6MJ)	1
Q2	3566	STRAIGHT FITTING (8MB X 6MJ)	1
S	3567	STRAIGHT FITTING (1/2 NPT X 6MJ, MALE)	1
T	3584	STRAIGHT FITTING (3/4MNPT X 16MJ)	2
U	3186	1/4" X 10' HOSE	2
V	420	GANTRY CYLINDER	1
W	3328	3 SPOOL CONTROL VALVE	1
SEE PAGE 21	3178	REUSABLE FITTING FOR 1/4" HOSE	14

- Test the operation of the system following the operating instructions on the next page.

**CAUTION!:** Use extra caution when first operating the system. Operate the system at a slow speed through it's full range of motion and inspect all hydraulic hoses to assure proper operation. Reroute and secure hoses as necessary.



**CORRECT**  
COVERED POSITION  
WITH ROLLER BAR  
RESTING ON BACK OF  
CONTAINER

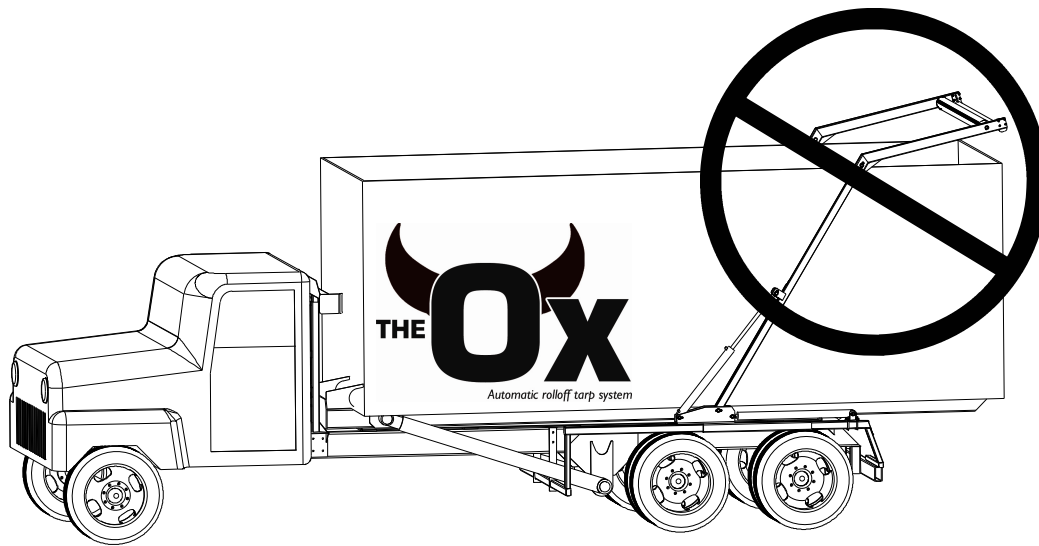

**INCORRECT**  
COVERED POSITION  
WITH ROLLER BAR  
ABOVE THE TOP OF  
CONTAINER

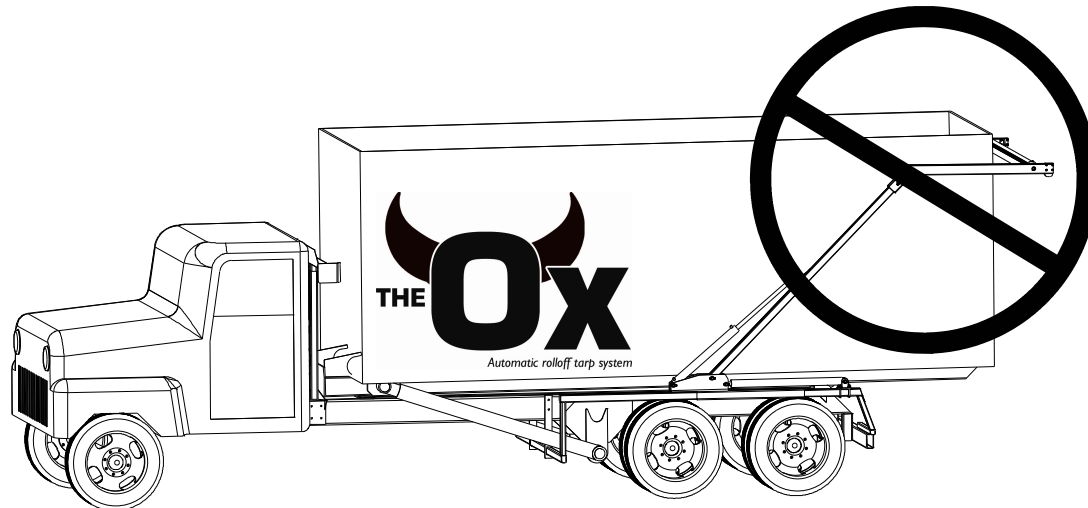

**INCORRECT**  
COVERED POSITION  
WITH ROLLER BAR  
BEHIND BACK OF  
CONTAINER

# OX SYSTEM OPERATING INSTRUCTIONS

**CAUTION:** BEFORE OPERATION OF ANY COVERING SYSTEM, CHECK OVER HEAD FOR POWER LINES, TREE LIMBS, OR OTHER OBSTACLES. MAKE SURE ALL PERSONNEL ARE CLEAR OF ALL MOVING PARTS.

## **IMPORTANT SAFETY INFORMATION**

ENSURE THE COVERING SYSTEM IS FULLY CLOSED IN THE STOWED POSITION BEFORE OPERATING THE HOIST OR MOVING TRUCK WITHOUT CONTAINER.

STEP 1. Using the spool control valve, raise the roller bar above the front edge of the container as shown below. Visually check the roller's position continually to keep from making contact with the container or the truck.

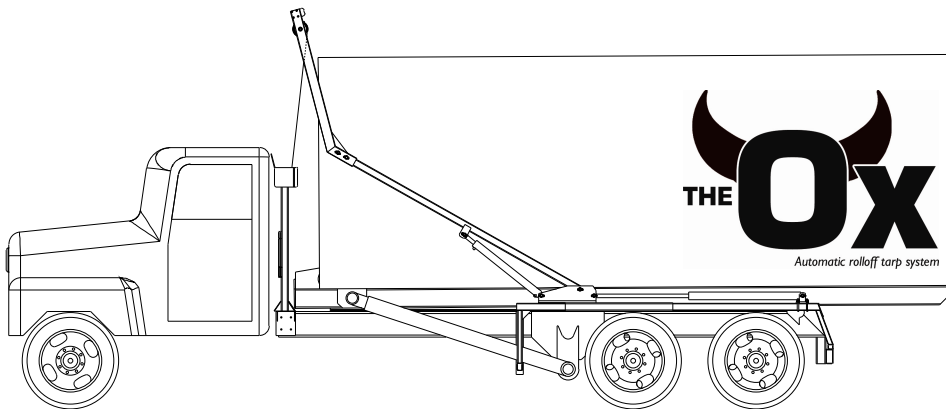

STEP 2. Next, rotate the arms back to cover the container, and rest the roller bar on the back edge of the container as shown below.

**NOTE:** The roller bar must always rest on the back edge of the container or in the cradle when the vehicle is in motion. Failure to do so will result in damage to the system and void the warranty.

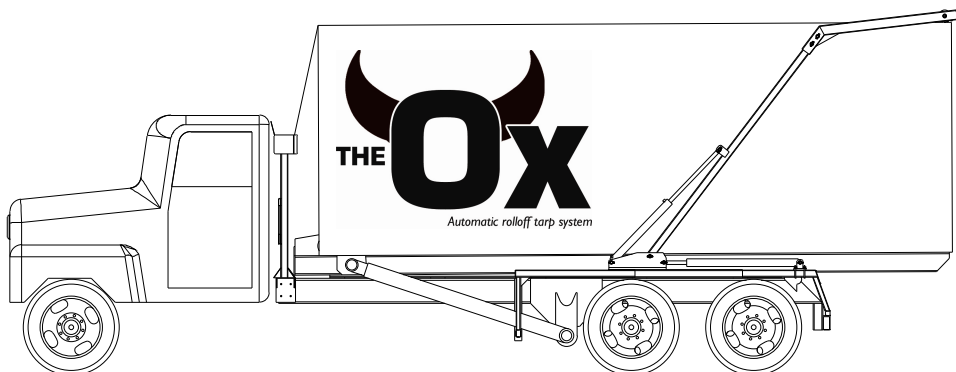

-To UNCOVER the container, reverse the previous two steps, and rest the roller in the cradle.



# **MAINTENANCE GUIDLINES**

## **DAILY:**

- Visually inspect the hydraulic and mechanical components.
- Check the hydraulic hose for wear, nicks, and kinks and ensure they are all clear of moving parts.
- Check the welds and mechanical components for any cracks or bent parts that could interfere with tarping operation.
- Check the tarp and bungee ropes for signs of damage or excessive wear and replace as needed.

**CAUTION:** Dirty hydraulic fluid will cause serious damage to the hydraulic tarping components as well as your truck's hydraulic parts. The cleaner the oil, the longer your hydraulic parts will last.

## **MONTHLY:**

- Lubricate each joint using a grease gun to insert grease into the grease fittings.
- Check hydraulic fluid to verify that it is clean

## **ANNUAL:**

- Change the fluid in the trucks hydraulic system at least annually at a minimum.

**DeBrovy's, 9016 Taylorsville Rd #108, Louisville KY 40299**

**800-718-2777**

**[www.debrovys.com](http://www.debrovys.com)**



# STICKER PLACEMENT

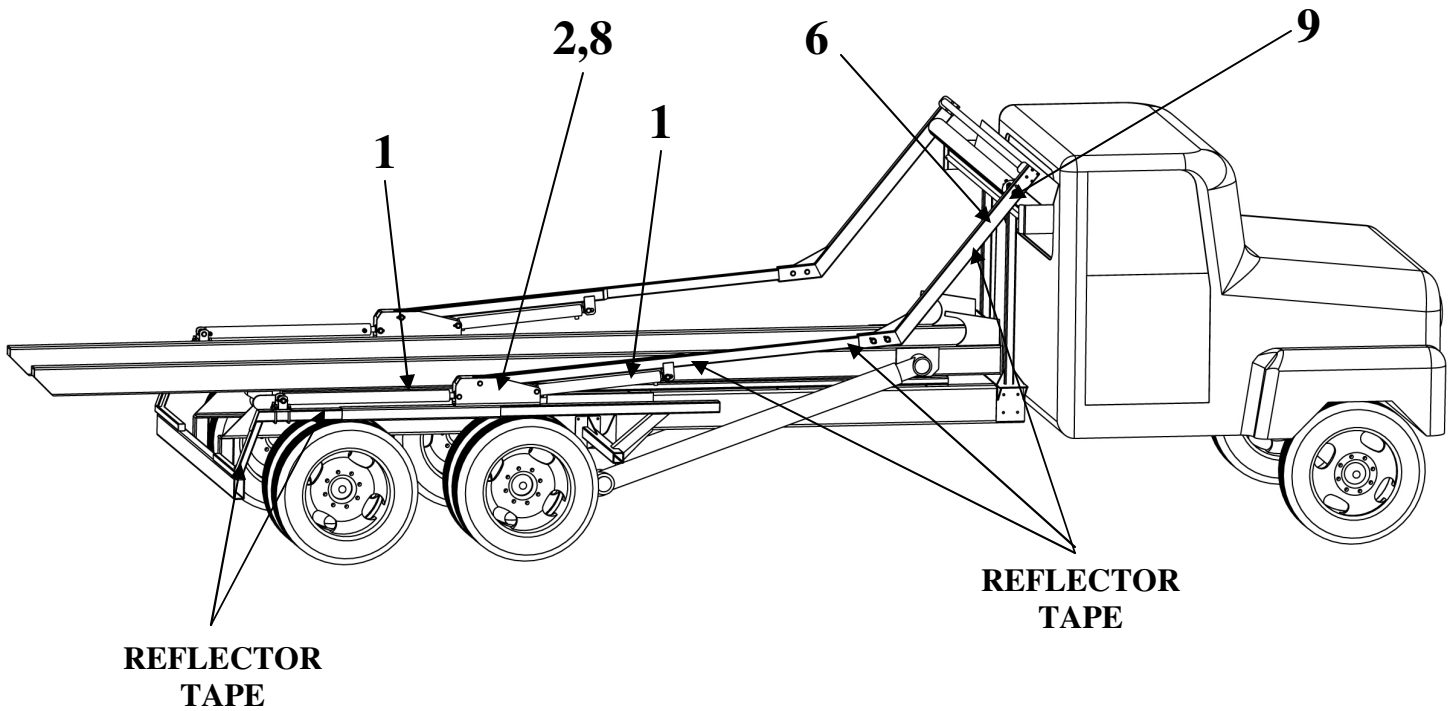
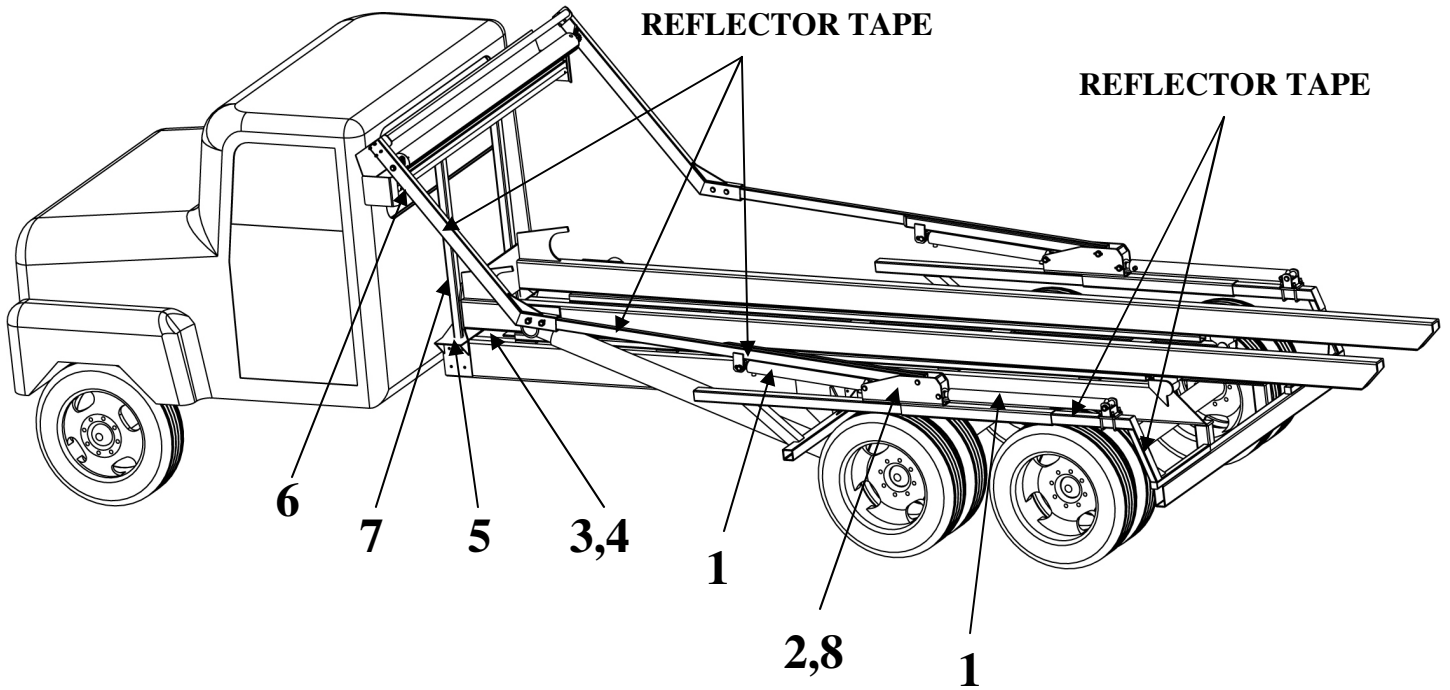

**NOTE: REFLECTOR TAPE is not supplied by Donovan Enterprises but is recommended.**

# STICKERS

**1**

**⚠ WARNING**

Escaping fluid under pressure can penetrate the skin causing serious injury or death. Relieve pressure before disconnecting hydraulic lines, tighten all connections before applying pressure and inspect all lines before each use. See "Safety" section in operation manual for additional information.

If an accident occurs, see a doctor immediately. Any fluid injected into the skin must be surgically removed within a few hours or gangrene may result.



**2**



**⚠ WARNING**

**CRUSHING HAZARD**

Moving parts can crush and cut. Keep hands and arms clear.

**3**

**NOTICE**

1. READ OPERATOR'S MANUAL PRIOR TO OPERATING THIS EQUIPMENT.
2. MUST HAVE MIN. 20 FEET OF OVERHEAD CLEARANCE.
3. Observer and practice all safety and operating rules as established by your company and those in the tarper owner's manual.

---

OPERATING INSTRUCTIONS

1. Be sure material is inside of the container sides before tarping load.
2. After lifting tarp off of gantry, move tarp slides forward to clear front corner of container.
3. Position gantry slightly below top front corner of container. (Telescoping gantry models only.)
4. Cautiously lower tarp onto container. Rest tarp roller on top of container door or as close to end of container as possible.
5. For transport of empty container or no container. Lower gantry to lowest position. Securely position tarp roller and arms in gantry cradle.

**IMPORTANT:**  
If tarp does not roll up evenly, return arms to gantry cradle and hold arm control lever down to synchronize arms.

Donovan Enterprises • 3353 SE Gran Park Way, Stuart, FL 34997  
800-327-8287 • www.donovan-ent.com

**4**

**⚠ DANGER**

**BE AWARE OF POWER LINES AND OVERHEAD OBSTRUCTIONS**

CONTACT BY THE TARPER OR CONTAINER COULD CAUSE SERIOUS INJURY OR DEATH TO THE OPERATOR AND OR BYSTANDERS.

**20 FT. CLEARANCE REQUIRED**

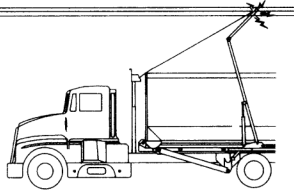

Donovan Enterprises • 3353 SE Gran Park Way, Stuart, FL 34997  
800-327-8287 • www.donovan-ent.com

**5**

**Donovan**  
ENTERPRISES  
*Tarps • Tarp Systems*

800-327-8287 • www.donovan-ent.com

UP ↑ GANTRY ↓ DOWN	COVER ↑ ARMS ↓ UNCOVER <small>Re-align</small>	FWD ↑ SLIDE ↓ BACK <small>Re-align</small>
--------------------------------	---	---

(Telescoping Gantry Models Only)

**6**

**⚠ WARNING**

**OPERATOR AND BYSTANDERS:**

STAND CLEAR OF ARMS DURING OPERATION! MOVEMENT OF ARMS MAY BE QUICKER THAN EXPECTED. CONTACT CAN CAUSE SERIOUS BODILY INJURY OR DEATH.



**7**

MODEL # 3074 / 3075

SERIAL # \_\_\_\_\_

US PATENT 5,752,735

Manufactured under license by:  
**Donovan Enterprises**  
Stuart, FL 34997  
1-800-327-8287

**Donovan**  
ENTERPRISES

www.donovan-ent.com

**9**

**ROTATE**

SPRING / SHAFT  
(AS SHOWN BY ARROW)  
TO INCREASE  
ROLLER SPRING  
TENSION  
DO NOT EXCEED  
35 TOTAL TURNS

OVER TENSIONING SPRING WILL  
DAMAGE SPRING AND VOID WARRANTY



**8**



by



STRONG

www.donovan-ent.com/oxstrong

Automatic rolloff tarp system