



# 2000SR Tarp Housing Installation Instructions

## STEP #1

### Required Parts:

PART #	Qty	Description	PART #	Qty	Description
1750	1	Housing (Left)	1328	2	Mounting angles
1751	1	Housing (Right)	99	1	Roller Bar
1377	1	Housing (Center)			

### Before beginning installation:

1. Check parts bags for correct contents. Contact your dealer if parts are missing. **THE LAST PAGE CONTAINS THE REFERENCE GUIDE FOR THE HARDWARE YOU WILL NEED TO INSTALL YOUR SYSTEM.**
2. Read through instructions for entire system to get a general idea of how each component is mounted and how the components fit together.

### Choosing the Mounting Location

In general, the tarp housing should be mounted on top of the trailer, as far forward as possible, so that the housing will be less likely to be damaged by loaders. Tarp housing should be mounted in a position to allow the pull bar to roll freely along the top rails of the sidewalls.

### Installing the housing

1. Once the mounting location has been determined, install the 2 mounting angles by welding or bolting on to the body. Position the mounting brackets such that the side of the bracket with the 2 holes is vertical and even with the outside width of the body. The side with no holes is cut on an angle so as not to catch on the tarp. The angle must be facing the rear of the body.

**NOTE:** mounting brackets have slotted holes for slight adjustments to square system and tarp with body.

2. Adjust the width of the housing by loosening the 5/16" carriage bolts in the slots located on the top and front of the tarp housing.
3. Extend or compress the housing to the outside width of the mounting brackets. Align the holes in the bracket with the holes in the housing and secure with 5/16" x 1" bolts, lock nuts, and flat washers, or by welding in place.

**NOTE:** the tarp housing is adjustable in width from 84" to 96" without modification. If narrower or wider tarp housing is needed, it will be necessary to remove the bolts and re-drill the housing.

# 2000SR Tarp Installation Instructions

## STEP #2

### Contents of kit:

PART #	Qty	Description
439	1	Aluminum Pull Bar (Standard)
900	1	Pull Rope with clip

PART #	Qty	Description
3704	1	Composite Pull Bar (Optional)
3702	1	Split Shaft Collar Weldment (Optional)

Tarp Ordered Separately

### Roller bar Pre-Loading

**Before installing the tarp, the roller bar must be pre-loaded.** To pre-load, rotate the roller bar in the direction indicated by the arrow sticker located on the left hand side of the roller bar. Ensure the lock pawl is engaged. Insert a phillips head screwdriver in to the tarp slot on the roller bar so that it locks against the housing, preventing the roller bar from rotating and losing the pre-load.

#### Pre-Load Recommendations

Tarp Length	Number of Turns
12'-16'	24-28
18'-22'	30-34
24'-28'	36-40
30'-32'	42-45

Number of turns is approximate. Add 3-5 turns at a time until the tarp retracts completely. For tarps with flaps use the next increment of turns for the given length of tarp being used. **WARNING:** Pre-loading the roller bar opposite the direction of the arrows will damage the spring. Do not exceed fifty turns of pre-load.

## Installing the tarp

1. Lay the tarp out flat insuring the top of the tarp is facing up and the 4" pocket is to the rear. To help identify the top side of the tarp, insure the side hems fold underneath and the 4" pocket is sewn with hem facing up.
2. Install the tarp into the roller bar by inserting the tarp spline into the tarp slot of the roller bar through the center void where there is a gap between the left hand roller bar outer and the right hand roller bar outer. If the void is not large enough to allow the tarp to be installed from the center void, clamp the roller bar in place, remove the phillips head screw driver from right hand side of the roller bar. Insert tarp spline into the right hand side of the roller bar. **NOTE:** when clamping roller bar in place, place the clamp within the first 2" of the driver's side of the roller bar. This will help prevent having to remove the clamp while installing the tarp.

## Adjusting roller bar spring tension

1. After the tarp is installed, it may be necessary to adjust the spring tension applied during the pre-load. To increase spring tension: use a 1" wrench on the square flats and rotate the ratchet clockwise while counting each full rotation. **WARNING:** Lock pawl must be fully engaged before wrench is removed to prevent injury.
2. To **DECREASE** spring tension: while holding a 1" wrench on the square flats, lift lock pawl to disengage it from ratchet. Rotate ratchet counterclockwise while counting each full rotation. **WARNING:** Lock pawl must be fully engaged before wrench is removed to prevent injury.

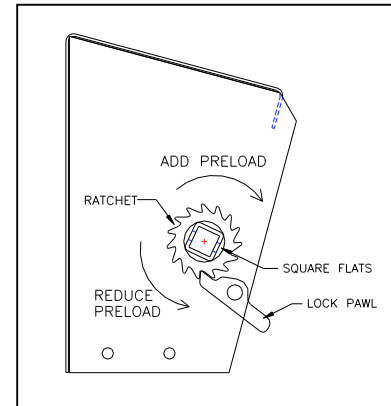

## Assembly of the pull-bar

1. Slide the 1" shaft collar to the middle of the pull bar and secure in place by tightening the set screw.
2. Insert the pull bar into the 4" pocket on the rear of the tarp.
3. Slide a 1" shaft collar onto each end of the pull bar; leave the set screw loose for final adjustment later.
4. Slide a 3" fender washer onto each end of the pull bar.
5. Slide a 1" x 6" PVC roller onto each end of the pull bar.
6. Slide the 5" fender washer onto each end of the pull bar.
7. Slide a 1" shaft collar onto each end of the pull bar; leave the set screw loose for final adjustment later.
8. A small slot must be made in the rear pocket of the tarp to attach the center pull rope to the pull bar. Measure the distance across the rear pocket of the tarp and mark the center point at the rear most edge of the pocket. Cut a small slot (approx 1/4") in the tarp at the center point. Align the slot with the center shaft collar on the pull bar. Remove the set screw in the shaft collar. Insert the eye bolt through the slot in the tarp pocket and into the shaft collar. Tighten eye bolt to secure shaft collar to pull bar. Clip the pull rope onto the eye bolt.

## Adjusting the pull bar width

1. The pull bar may require an adjustment in width due to variations in body width and side wall thickness. PVC Rollers on the pull bar should be centered over top rail of each side. If roller positioning needs adjustment, it is only necessary to adjust one side.
2. Slide the passenger side outer shaft collar to within 1" of the end of the pull bar. Apply included Loc Tite on shaft collar set screw and secure in place. Slide all remaining passenger side hardware against the outer shaft collar (5" fender washer, PVC roller, 3" fender washer, 1" inner shaft collar), and secure the inner shaft collar by applying Loc Tite and tightening the set screw. Ensure the PVC roller is centered on the passenger side top rail.
3. Align the driver's side PVC roller on the center of the rail and secure the shaft collars as in step 2 above. Cut off any excess pull bar ensuring that you leave at least 1" of pull bar extending beyond the outer shaft collar.
4. Loosen the center eye bolt and adjust as necessary to center the tarp on the pull bar.

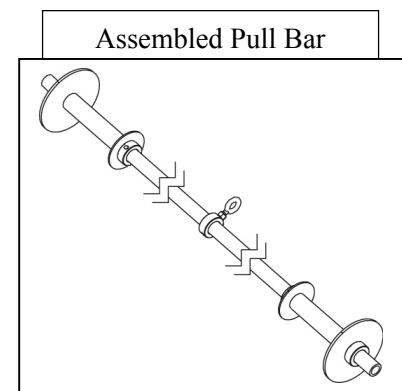

## Side wall modifications

1. It may be necessary to build up or modify sides of body to allow the pull bar to roll smoothly from the tarp housing along the top rail of the body and over the tailgate latch. This may be done using wood or metal to raise the entire side height or act as a ramp to transition the pull bar over obstacles such as tailgate hinges. **NOTE:** using steel wire cable is an excellent way to fabricate a ramp for the rollers to transition over. Weld or bolt one end of the cable to the top rail and one end to the top of the obstacle to transition over. If the obstacle is the tailgate hinge, cable will flex out of the way when the tailgate is raised.

# 2000SR

## Tailgate latches and rope hooks

## STEP #3

### Contents of kit:

<b>PART #</b>	<b>Qty</b>	<b>Description</b>
660	2	Steel tailgate latches
62	4	“J” hooks

### Installing the tailgate latches

1. Mount (weld or bolt) the tailgate latch to the top edge of the tailgate in a location that allows the pull bar to transition smoothly over the tailgate and latch under the tailgate latch. Spring tension in the roller bar will lock the pull bar snugly against the tailgate latch.

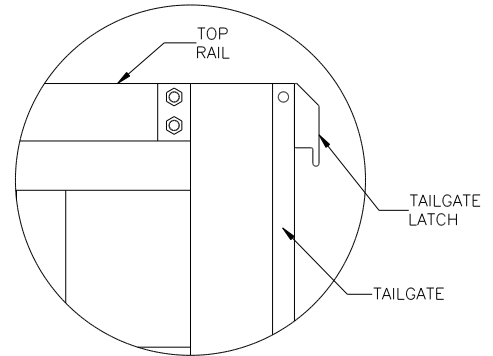

### Installing the rope hooks

1. Weld or bolt two “J” hooks to the tailgate far enough apart to allow the entire length of the pull rope to be stored when the tarp is fully extended.
2. Mount another set of “J” hooks to the front driver’s side of the body or trailer far enough apart to allow the entire length of tarp rope to be stored when the tarp is fully retracted.

# 2000SR

## Hardware Kit

### Mounting angle bracket hardware

<b>PART #</b>	<b>Qty</b>	<b>Description</b>
2469	4	3/8” x 1” bolt
2874	4	3/8” Lock nut
2875	4	3/8” Flat washer

### Pull bar hardware

<b>PART #</b>	<b>Qty</b>	<b>Description</b>
2454	1	5/16” x 1 1/4” Eye bolt with nut
92	2	1” x 3” Fender washer
3809	2	1” x 5” Fender washer
40	5	1” Shaft collar
3858	1	Loc Tite (small tube)
2451	2	1” x 6” PVC roller