

# BULLET



**Installation Instructions**  
**Models 2858, 2858A-1, 2858GL**  
**February 2009**



[www.debrovys.com](http://www.debrovys.com)  
DeBrovy's • 9016 Taylorsville Rd. #108 • Louisville, KY 40299  
800-718-2777

# Step 1



## Head Assembly Installation Instructions

### **Before beginning installation:**

- 1) Check parts bags for correct contents. Contact your dealer if parts are missing. **THE LAST PAGE CONTAINS THE REFERENCE GUIDE FOR THE HARDWARE YOU WILL NEED TO INSTALL YOUR SYSTEM.**
- 2) Read through instructions for entire system to get a general idea of how each component is mounted and how the components fit together.

### **Choosing the Mounting Location**

In general, the rollerbar should be mounted on top of the cab shield as far forward as possible so that the pivot arms will be less likely to be damaged by loaders. If head assembly is mounted too far forward, the pivot arms may interfere with the truck doors.

**Exceptions:** Trucks with vertical stacks. Vertical stacks may be in the way of the pivot arms if the rollerbar were to be mounted forward of the stack(s). Simply shortening or re-aligning the stack(s) may solve the problem. If the stack(s) still get in the way, it may be necessary to mount the rollerbar to the rear of the stack(s). If there is not room to mount the rollerbar on the cab shield behind the stacks, they will need to be mounted on top of the side board pockets to the front of the body.

### **Installing the Bearing Plates (Optional)**

- 1) Once, the mounting location has been determined, you may either install the bearing plates using the 3/8" x 1-1/2" bolts, flat washers, and lock nuts, or use the bearing plates as templates to drill the necessary mounting holes into the cab shield sides or other suitable location.
- 2) If you chose to use the bearing plates as templates and mount directly to the cab shield, remove the 3/4" bearing from the passenger side bearing plate and bolt it in place on the cab shield.  
**Note:** The bearing plates or cab shield holes should be exactly opposite of each other to avoid the tarp bunching to one side during use.
- 3) Be sure there is enough clearance between the rollerbar and the cab shield to roll-up the entire tarp.

**Note:** If you are installing Model #2858GL, refer to the "GL Install Packet" (included) at this time and install the ground level crank assembly.

### **Mounting the Direct Drive (DD) Motor and Rollerbar**

- 1) Mount the DD motor to the bearing plate or cab shield.
- 2) Measure from the inside of one bearing plate to the inside of the other bearing plate. Cut the roller bar on the end without the pre-drilled hole one inch shorter than this length.
- 3) Drill a 3/8" hole, 1/2" from each end of the rollerbar you just cut. Start the hole in one of the smooth-sided slots (see Figure 1). Slide one end of the rollerbar over the DD motor output shaft and secure with a 5/16" carriage bolt, washer, and nut.
- 4) Slide the extension shaft through the bearing plate and into the roller bar. Line up the holes in the rollerbar with the hole in the extension shaft and secure with the 5/16" carriage bolt, washer, and nut.

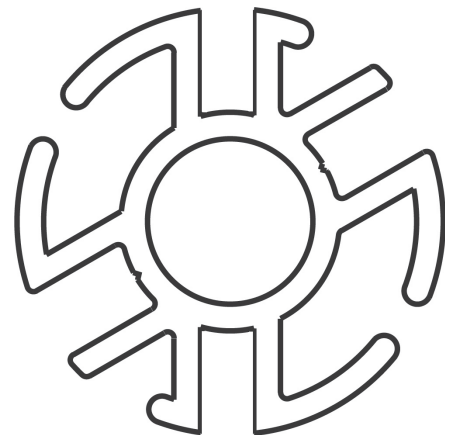

## **Installing the Wind Deflector (Optional)**

Install the wind deflector halves to the cab shield using the 3/8" x 1-1/2" bolts, flat washers, & lock nuts. Mount the wind deflector forward of the rollerbar allowing enough space between the wind deflector and the rollerbar for the tarp when it is fully rolled up. One or both halves may need cutting to fit the width of the cab shield. It may also be necessary to cut notches in the wind deflector for the cab shield support braces.

## **Wiring the Motor**

**CAUTION:** The motor **must** be wired using the 8-gauge wire provided or a heavier gauge. Smaller wire will cause the system to operate slowly and possibly overheat.

**Hint:** Running 3/4" EMT conduit down the front of the body and back along the frame rail provides a safe place to run the wires as well as adding a clean, finished look to the installation.

## **Wiring the Control Box**

Follow the Wiring Instruction provided with your electrical switch kit.

# Step 2



## Pivot Mount Installation instructions

### Contents of Kit:

- |                         |                      |
|-------------------------|----------------------|
| 2 Lower Pivot Arms      | 2 Pivot Arm Mounts   |
| 8 Flat Torsion Springs  | 2 1-1/4" x .047 Shim |
| 2 1-1/4" Retaining Ring |                      |

### Installation Instructions

- 1) To find the pivot point, pull one tape measure from point "A" and a separate tape measure from point "B". Next, cross the tape measures at the bottom-middle of the truck body where the two measurements are equal - mark the spot beneath where they cross. This is your pivot point. (See Figure 1)
- 2) Determine proper orientation of pivot mount plate following page 1, paragraph 2 and figure 2 (below).
- 3) Weld or bolt pivot mounts in place. If bolting, use the pivot mount as a guide to determine the hole position for mounting, ensuring the center of the mounting plate is aligned with the pivot point as determined in step 1. Drill two 9/16" holes in line with the holes on the pivot mount on each side of the box. Bolt the pivot mounts to the box using the included 1/2" carriage bolts, flat washers and lock nuts (the head of the bolt must be on the outside, and the washer and nut on the inside). Ensure pivot mount is oriented properly.

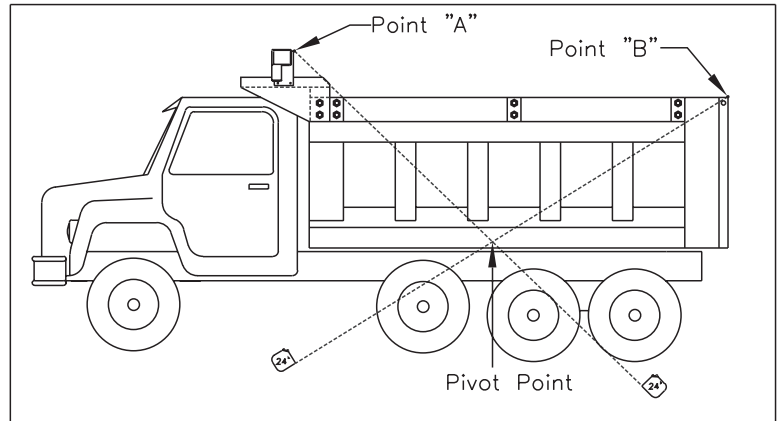

FIGURE 1

**CAUTION:** Failure to comply with the above instructions could cause severe damage to the system.

# Step 3



## Pivot Arm Installation instructions

### Contents of Kit:

- |                          |                              |
|--------------------------|------------------------------|
| 2 Upper Pivot Arms       | 2 90° Elbows                 |
| 1 Rear Cross Piece (RCP) | 2 Pivot Arm Rests (Optional) |
| 1 Rubber Tarp Stops      |                              |

### Installing the Pivot Arms (Straight Arms - Models #2858 & 2858GL)

If you are installing 30° bend arms (#2858A-1) skip to the next section

- 1) You may choose to install the lower arms on the pivot mounts without flat torsion springs. This will simplify the rest of the installation because the pivot arms may now be moved and adjusted without spring tension.
- 2) Slide one of the upper pivot arms into a lower arm. Adjust the arm length until the corner rests on the desired landing point at the back of the box (Point "B", figure 1 from 'Pivot Installation Instructions' on previous page). If the upper arm is too long, cut both upper arms to allow at least 2 feet of upper pivot arm sticking into the lower pivot arm.
- 3) Attach the other lower arm assembly, again leaving the springs off to allow for ease of arm adjustment.
- 4) Slide both upper pivot arms into the lower pivot arms (make sure that both upper arms end up the same length) and lightly tighten the two bolts which hold each upper arm into the lower arm. Final tightening will be done later.
- 5) Measure the distance between the upper arms as in Figure 3. Cut the end of the rear cross piece that **does not** already have the holes 2" shorter than the distance measured. Using the pre-drilled bolt holes in the 90° bend castings as a template, mark the rear cross piece for drilling. Drill two 3/8" holes in the rear cross piece at these markings such that when the casting is inserted into the rear cross piece the holes will align to allow bolting.
- 6) Insert 90° elbows into upper arms. Slide the ends of the rear cross piece over the 90° elbow castings.
- 7) Secure the rear cross piece and upper arms to the elbows with the included T-nuts and bolts.
- 8) Swing the complete pivot arm assembly forward until it rests on the head assembly. The rear cross piece should be resting in the center of the head assembly opening (see Figure 4). If the rear cross piece is **not** landing the center of the opening, loosen the 4 bolts that hold the upper arms into the lower arms and adjust where the rear cross piece lands. Lightly re-tighten the bolts.
- 9) Swing the pivot arm assembly back to the rear of the truck and check the landing position. If it appears that the rear cross piece will interfere with the operation of the tailgate, the pivot point may need to be moved or mount the pivot arm rests (pivot arm rest installation discussed later) so the rear cross piece remains clear of the tailgate.
- 10) Check for binding or rubbing of the pivot arms against the sides of the box. Check both sides of

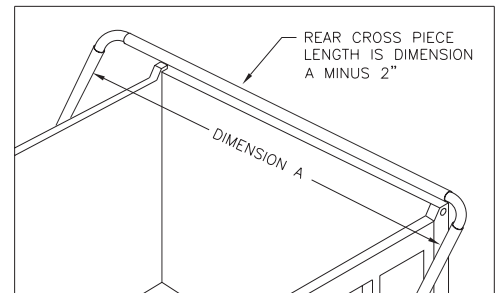

FIGURE 3

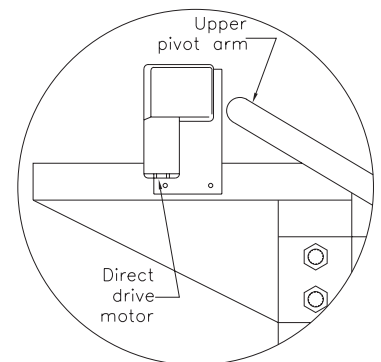

FIGURE 4

the box, and adjust the pivot mounts or arms as necessary for clearance.

- 11) Mark both upper arms where they slide into the lower arms. This will allow you to reassemble the arms without re-measuring.
- 12) Remove the rear cross piece, lower and upper arms so that you may reinstall the flat torsion springs. (If you previously removed them)
- 13) Remount the lower pivot arms with the flat torsion springs (4 per side). Make sure the hook ends of the springs have clipped over the pin in the spring guard. Place the 1-1/4" shim over pivot mount shaft. Place the spring clip back onto the pivot mount shaft.
- 14) Slide the upper arms into the lower pivot arms to the marks made in Step 11 and tighten the bolts that hold them in place.

### **Installing the Tarp**

- 1) Thread the tarp spline into the aluminum rollerbar. (Make sure to remove excess spline or it may hinder the system's operation.)
- 2) Slide the rear cross piece into the tarp pocket (sewn into the tarp).
- 3) Center the tarp on both aluminum roller bar and rear cross piece.
- 4) Slide one rubber bumper over one end of rear cross piece until hole in bumper aligns with bolt hole in rear cross piece. Repeat at other end.
- 5) Using hardware supplied with the rubber bumper kit, bolt the rear cross piece to the 90° elbows on each pivot arm.
- 6) Re-check all mechanism bolts and screws for security.

### **Installing the Pivot Arm Rests (Optional)**

- 1) Unwind the tarp so that the system is in the "covered" configuration.
- 2) Position the pivot arm rests so that upper arms are as level as possible and do not make contact with the tailgate or any other part of the dump body.
- 3) Weld or bolt pivot arm rests into place.



# Hammer, Bullet, 7000 series

## GROUND LEVEL

### Installation Instructions

#### (Rollerbar & GL Crank Assembly)

# STEP #1

#### Required Parts:

1	3/4" Extension Shaft with Sprocket	1	Chain Guard, Lower
1	3/4" Extension Shaft	1	Chain Guard, Upper
1	7000GL Control Box Assembly	3	Chain Guard Bracket
		2	3/4" Shaft Collar

#### Mounting the GL Control Box

- 1) Determine suitable position for mounting GL control box to front driver's side of body. Keep in mind that the top sprocket and bottom sprocket must align vertically without any obstacles to obstruct movement of the chain or crank handle.
- 2) Mount control box to side wall of body using 3/8" x 1-1/2" bolts, lock nuts, and flat washers.

#### Mounting the Rollerbar, Sprocket Shaft and Chain

- 1) Measure from the inside of one bearing plate to the inside of the other. Cut end of roller bar, without pre-drilled hole, one inch shorter than this length.
- 2) Drill a 5/16" hole, 1/2" from the end of the rollerbar that you just cut.
- 3) Slide the extension shaft through the curb-side bearing plate and into the roller bar. Line up the holes in the roller bar with the hole in the extension shaft and secure with the 5/16" carriage bolt, flat washer, and lock nut.
- 4) Install a 3/4" shaft collar onto the extension shaft on the outside of the 3/4" bearing to prevent lateral movement of the roller bar.
- 5) Slide the 3/4" shaft collar on the extension shaft with the sprocket and then slide the extension shaft through the bearing plate and into the roller bar. Align the sprocket by sliding the shaft into or out of the rollerbar such that when the chain is installed, it is going straight up from the control box to rollerbar sprocket. Tighten shaft collar set screw.
- 6) Using the hole you drilled in step 2 as a guide, drill a 5/16" hole through the sprocket shaft. Secure the shaft to the rollerbar using a 5/16" x 2-1/2" carriage bolt, flat washer, and lock nut.
- 7) Assemble chain around top and bottom sprocket, removing unnecessary links as needed to adjust chain length. Once desired length and tension are achieved, fasten chain together using included master chain link.

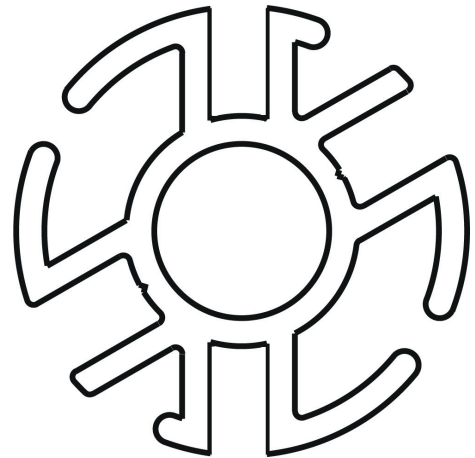

#### Installing the Chain Guard

- 1) Entire chain guard assembly can be welded together and to truck. If welding skip the rest of this section. If bolting, proceed to step 2.
- 2) Mount chain guard by overlapping upper chain guard over lower chain guard and attaching them together using 3/8" x 1/2" bolts, lock nuts, and six 1/4" self drilling screws
- 3) Lower chain guard attaches to control box with 1/4" by 1/2" bolts and lock washers.
- 4) Secure chain guard to truck body with chain guard brackets using the 1/4" self-drilling screws (2 per bracket).

**DeBrovy's**  
**9016 Taylorsville Rd #108**  
**Louisville, KY 40299**  
**1-800-718-2777**



## Parts and Hardware

	Qty	Part #
<b>BULLET Aluminum System, Complete</b>		
Part # 2858, 2858A-1, 2858-GL		
<b>Pivot Arm, L/H, Lower Assembly</b>		
	1	8001
<b>A</b>	1	3211
<b>B</b>	1	1787
<b>C</b>	4	2416
<b>D</b>	1	2834
<b>E</b>	1	2833
<b>Pivot Arm, R/H, Lower Assembly</b>		
	1	8002
	1	3211
	1	1787
	4	2416
	1	2834
	1	2833
<b>Pivot Arm, L/H, Upper, w/90 Elbow</b>		
	1	3244
<b>F</b>	1	3279
<b>G</b>	1	2842D
<b>Pivot Arm, R/H, Upper, w/90 Elbow</b>		
	1	3245
	1	3279
	1	2842D
<b>I</b>	1	3279
<b>J</b>	1	3270Z
	2	3270Z
<b>K</b>	1	61L
	1	2848
<b>L</b>	1	3678Z
	1	89
<b>Q</b>	1	2365
<b>R</b>	1	2838
	2	3771N
	1	85N

### Pivot Assembly Hardware

Description	Qty	Part #
Bolt, hex, 3/8" x 1 1/2"	8	2464
Washer, flat, 3/8"	8	2875
Nut, hex lock, 3/8"	8	2874
Bolt, allen head, 1/4" x 1 1/4"	4	1914
Nut, tee, 1/4"	4	1915
Bolt, carriage 1/2" x 1 1/2"	4	4437
Washer, flat, 1/2"	4	2878
Nut, hex lock, 1/2"	4	2877
5mm Allen Wrench	1	3556

### Head Assembly Hardware

Description	Qty	Part #
Shaft Extension, 3/4" x 4"	1	2838
Bolt, hex, 3/8" x 1 1/2"	8	2464
Washer, flat, 3/8"	8	2875
Nut, hex lock, 3/8"	8	2874
Bolt, carriage, 5/16" x 2 1/2"	2	3237
Nut, hex lock, 5/16"	2	2868
Washer, flat, 5/16"	2	2867
Bolt, hex, 5/16" x 3/4"	3	2418
Screw, Sheet metal #10 x 3/4"	2	3709
Shaft Colar 3/4" (GL only)	1	450

### Options

Bullet with 30° Bent Arm	Qty	Part #
Pivot Arm, L/H, Upper,	1	1190
Pivot Arm, R/H, Upper,	1	1191
Bolt, Allen Head, 1/4" x 1 1/2"	4	1914
Nut, tee, 1/4"	4	1915
Pivot Arm Mount R/H offset	1	1729
Pivot Arm Mount L/H offset	1	1730
<b>H</b> Pivot Arm Rest Assembly	2	3218
Pivot Arm Rest	2	3361
Bumper, Rubber	2	2948
<b>M</b> Wind Deflector, Aluminum	1	1216
Durabuilt Solenoid Switch Kit	1	1495
(Includes solenoid, rocker switch bracket, breaker and connectors)		





# Parts and Hardware

